

# Instruction Manual

## XRF SERIES

### High Voltage Power Supply

MODEL :  
SERIAL# :  
DATE :

**SPELLMAN  
HIGH VOLTAGE ELECTRONICS  
CORPORATION**

475 Wireless Blvd.  
Hauppauge, New York, 11788

+1(631) 630-3000\*FAX: +1(631) 435-1620\*  
E-mail: [sales@spellmanhv.com](mailto:sales@spellmanhv.com)  
Website: [www.spellmanhv.com](http://www.spellmanhv.com)



- **160KV OUTPUT VOLTAGE**
- **RACK-MOUNTABLE**
- **FLOATING FILAMENT**
- **INTERNAL GRID POWER SUPPLY (80W MODEL)**
- **POWER FACTOR CORRECTION**
- **CLOSED-LOOP EMISSION CONTROL**
- **OEM CUSTOMIZATION AVAILABLE**

[www.spellmanhv.com/manuals/XRF](http://www.spellmanhv.com/manuals/XRF)

Spellman's XRF Series allow for a wide range of input voltages and supply either 80W, 320W or 640W of output power at up to 160kVdc. These lightweight rack-mountable X-ray generators house a miniaturized high voltage system in a solid encapsulated, oil-free design. The XRF Series is designed with a power factor corrected input circuit which reduces harmonic emissions and noise normally associated with other high frequency switching power supplies. The XRF Series incorporates an internal floating filament and a closed-loop emission control circuit for precise regulation of emission current. Remote monitoring and control of voltage, current and filament current is also provided.

### TYPICAL APPLICATIONS

X-ray Inspection  
Non-Destructive Testing

### OPTIONS

|                                      |                                  |
|--------------------------------------|----------------------------------|
| <b>AOL</b> Adjustable Overload       | <b>DF</b> Dual Filament          |
| <b>GS</b> Grid Supply                | <b>SL</b> Slides                 |
| <b>PC</b> Power Control              | <b>APT</b> Adjustable Power Trip |
| <b>AT</b> Arc Trip                   | <b>IO</b> Instant ON             |
| <b>SS(X)</b> Non Standard Slow Start |                                  |

### SPECIFICATIONS

#### Input Voltage:

80W: 90-125 and 180-264Vac at 48-62Hz.  
320W: 180-264Vac at 48-62Hz.  
640W: 180-264Vac at 48-62Hz.

#### Power Factor:

0.9 or better.

#### High Voltage Supply:

**Output Voltage:**  
0-160kV, negative polarity.

**Output Current:**  
80W: 0.5mA max.  
320W: 2.0mA at 160kV; 3.0mA at 100kV.  
640W: 4.0mA.

**Output Voltage Stability:**  
Within 0.1% of set value after warm-up period at full load.

**Output Voltage Ripple:**  
80W & 320W: <0.1%, or 160V p-p for high freq. and line freq. at full load.  
640W: 0.03% rms <1kHz, 0.75% rms above 1kHz.

**Beam Current Stability:**  
80W: Within 0.1% of set value after 1/2 hour warm-up at constant output setting of 30-160kV and line voltage of 90-125 & 180-264Vac.  
320W & 640W: Same as 80W except line voltage of 180-264Vac.

**Filament Supply:** Constant current DC filament supply with closed-loop current feedback.  
**Filament Voltage:** 7V rms (high frequency) max.  
**Filament Current:** 5A max., adjustable 0-5.0A by external Filament Limit Programming input.

#### Floating Grid Power Supply (80W Unit Only):

**Grid Supply:** The grid supply controls tube beam current in a closed-loop regulation design.  
**Grid Voltage:** 0 to 1200Vdc.  
**Grid Voltage Ripple:** Less than 1.0V rms at any frequency.  
**Grid Supply Response:** Less than 0.5mA in less than 10ms.

#### Control and Monitoring:

**Analog Control Inputs:** Three inputs have internal load resistance greater than 330kohms.

#### Voltage Programming:

80W & 640W: 0 to +10Vdc, where 10.0Vdc = 160kV output.  
320W: 0 to +10Vdc, where 8.0Vdc = 160kV output.

#### Beam Tube Current Control:

80W: 0 to +10Vdc, where 10.0Vdc = 0.5mA tube current.  
320W: 0 to +6Vdc, where 6.0Vdc = 3.0mA tube current.  
640W: 0 to +10Vdc, where 10.0Vdc = 4.0mA tube current.

#### Filament Current Control:

0 to +10Vdc, where 5.0Vdc = 5.0A filament current.

#### Analog Monitor Outputs:(See Tables For Details)

80W, 320W, 640W: High Voltage and Beam Current Monitoring.  
80W: Filament Current Monitoring.  
320W & 640W: Internal filament current monitor test point not connected to the interface connector.

#### Digital Control Inputs:(See Tables For Details)

80W, 320W, 640W: Interlock Enable.  
80W, 320W, 640W: HV Enable.  
80W: Grid Inhibit.  
640W: Filament Select.

#### Digital Outputs:(See Tables For Details)

HV ON.  
Voltage Mode.  
Current Mode.

#### Connections:

**Output Connector:** 160kV European Conical connector with 2-ring and center pin end.  
**Input Power Connector:** 5-pin male MS-type, Amphenol P/N 97-3102A-18-20P  
**Control Connections:** 25-pin "D" connector, male, chassis-mounted.

**Environmental:**

0 to +50°C at 10-95% RH, non-condensing.  
Forced convection cooling.

**Dimensions:**

7"H x 19"W x 22"D. (17.8cm x 48.3cm x 55.9cm).

**Regulatory Approvals:**

Compliant to 2004/108/EC, the EMC Directive and 2006/95/EC, the Low Voltage Directive.

**160kV XRF SELECTION TABLE**

| OUTPUT VOLTAGE<br>kV | OUTPUT CURRENT<br>mA | OUTPUT POWER<br>W | MODEL NUMBER<br>XRFxxx |
|----------------------|----------------------|-------------------|------------------------|
| 160                  | 0.5                  | 80                | XRF160N80              |
| 160                  | 2.0                  | 320               | XRF160N320             |
| 160                  | 4.0                  | 640               | XRF160N640             |

**J2—AC INPUT CONNECTOR WIRING**

| 5 Pin MS Type | 7 Pin UTG Type | CONNECTION                |
|---------------|----------------|---------------------------|
| A             | 1              | Auxiliary (Logic) Line    |
| B             | 2              | Auxiliary (Logic) Neutral |
| C             | 3              | Ground                    |
| D             | 4              | Main (Inverter) Line      |
| E             | 5              | Main (Inverter) Neutral   |

**160kV XRF 80W, 320W, 640W, 25 PIN**

| JB1 | SIGNAL                   | SIGNAL PARAMETERS                            |
|-----|--------------------------|--|
| 1   | Filament Limit           | 0-5V=0-5A Filament Limit                     |
| 2   | High Voltage on Control  | +12VDC IN = HV ON                            |
| 3   | N/C                      |  |
| 4   | N/C                      |  |
| 5   | High Voltage On Status   | Open=HV ON for 320W, Low=HV ON for 80W       |
| 6   | A-Ground                 | Ground                                       |
| 7   | kV Monitor               | 0-8V=0-160kV for 320W, 0-10V=0-160kV for 80W |
| 8   | Interlock Control        | +12VDC IN = Interlock Closed                 |
| 9   | N/C                      |  |
| 10  | mA Demand                | 0-6V=0-3mA for 320W, 0-10V=0-0.5mA for 80W   |
| 11  | N/C                      |  |
| 12  | N/C                      |  |
| 13  | D-Ground                 | Ground                                       |
| 14  | Fil. Monitor             | 0-5V=0-5A rms                                |
| 15  | N/C                      |  |
| 16  | N/C                      |  |
| 17  | N/C                      |  |
| 18  | N/C                      |  |
| 19  | mA Monitor               | 0-6V=0-3mA for 320W, 0-10V=0-0.5mA for 80W   |
| 20  | N/C                      |  |
| 21  | +12VDC Out               |  |
| 22  | kV Demand                | 0-8V=0-160kV for 320W, 0-10V=0-160kV for 80W |
| 23  | Grid Inhibit/Fil. Select | (Low=Grid Inhibit), Low=small spot size      |
| 24  | N/C                      |  |
| 25  | Chassis Gnd (I/O Shield) | Chassis Gnd.                                 |

DIMENSIONS: in.[mm]

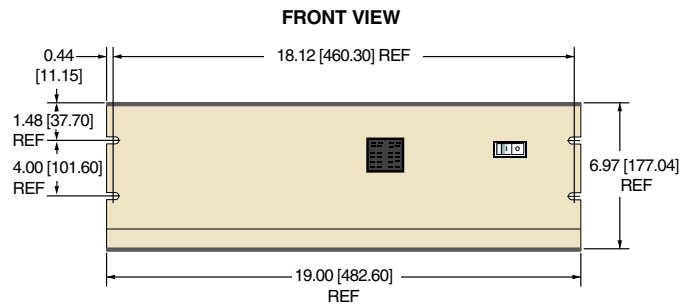

TOP VIEW

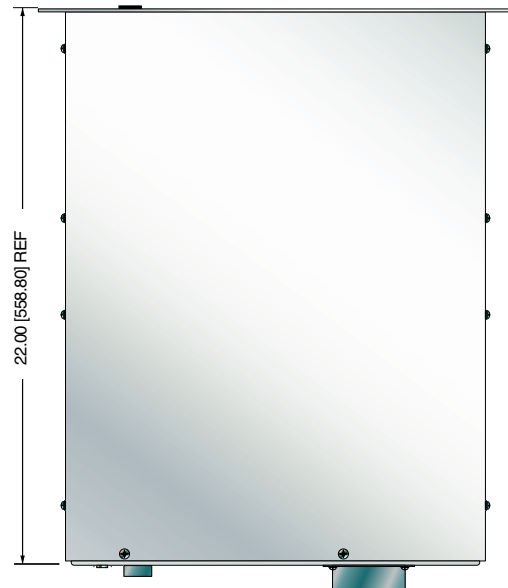

BACK VIEW

**160kV XRF 80W, 320W, 640W TERMINAL BLOCK 10 PIN**

| TB1 | SIGNAL                 | SIGNAL PARAMETERS                            |
|-----|------------------------|--|
| 1   | Interlock              | Jumper to TB2 to close interlock             |
| 2   | Interlock Return       |  |
| 3   | kV Monitor             | 0-8V=0-160kV for 320W, 0-10V=0-160kV for 80W |
| 4   | mA Monitor             | 0-6V=0-3mA for 320W, 0-10V=0-0.5mA for 80W   |
| 5   | Filament Monitor       | 0-5V=0-5A rms                                |
| 6   | Bias Monitor           | Status Only. No Scale Factor(optional)       |
| 7   | HV ON Indicator        | +15V=HV ON                                   |
| 8   | Voltage Mode Indicator | Low=Voltage Mode.                            |
| 9   | Current Mode Indicator | Low=Current Mode.                            |
| 10  | GND                    | Ground                                       |

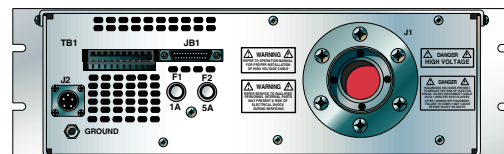

USA +1-631-630-3000  
UK +44 (0)1798 877000  
JAPAN +81 (0)48-447-6500  
CHINA +86 (0)512-67630010

FAX: +1-631-435-1620  
FAX: +44 (0)1798 872479  
FAX: +81 (0)48-447-6501  
FAX: +86 (0)512-67630030

e-mail: sales@spellmanhv.com  
www.spellmanhv.com

128013-001 REV.F

Spellman High Voltage is an ISO 9001:2000 and ISO 14001:2004 registered company

## IMPORTANT SAFETY PRECAUTIONS

### SAFETY

THIS POWER SUPPLY GENERATES VOLTAGES THAT ARE DANGEROUS AND MAY BE FATAL.  
OBSERVE EXTREME CAUTION WHEN WORKING WITH THIS EQUIPMENT.

High voltage power supplies must always be grounded.

Do not touch connections unless the equipment is off and the Capacitance of both the load and power supply is discharged.

Allow five minutes for discharge of internal capacitance of the power supply.

Do not ground yourself or work under wet or damp conditions.

### SERVICING SAFETY

Maintenance may require removing the instrument cover with the power on.

Servicing should be done by qualified personnel aware of the electrical hazards.

**WARNING** note in the text call attention to hazards in operation of these units that could lead to possible injury or death.

**CAUTION** notes in the text indicate procedures to be followed to avoid possible damage to equipment.

Copyright © 2000, Spellman High Voltage Electronics Corporation. All Rights Reserved.  
This information contained in this publication is derived in part from proprietary and patent data. This information has been prepared for the express purpose of assisting operating and maintenance personnel in the efficient use of the model described herein, and publication of this information does not convey any right to reproduce it or to use it for any purpose other than in connection with installation, operation, and maintenance of the equipment described.

# WICHTIGE SICHERHEITSHINWEISE

## SICHERHEIT

DIESES HOCHSPANNUNGSNETZTEIL ERZEUGT LEBENSGEFÄHRLICHE HOCHSPANNUNG.  
SEIN SIE SEHR VORSICHTIG BEI DER ARBEIT MIT DIESEM GERÄT.

Das Hochspannungsnetzteil muß immer geerdet sein.

Berühren Sie die Stecker des Netzteiles nur, wenn das Gerät ausgeschaltet ist und die elektrischen Kapazitäten des Netzteiles und der angeschlossenen Last entladen sind.

Die internen Kapazitäten des Hochspannungsnetzteiles benötigen ca. 5 Minuten, um sich zu entladen.

Erden Sie sich nicht, und arbeiten Sie nicht in feuchter oder nasser Umgebung.

## SERVICESICHERHEIT

Notwendige Reparaturen können es erforderlich machen, den Gehäusedeckel während des Betriebes zu entfernen.

Reparaturen dürfen nur von qualifiziertem, eingewiesenem Personal ausgeführt werden.

“WARNING” im folgenden Text weist auf gefährliche Operationen hin, die zu Verletzungen oder zum Tod führen können.

“CAUTION” im folgenden Text weist auf Prozeduren hin, die genauestens befolgt werden müssen, um eventuelle Beschädigungen des Gerätes zu vermeiden.

# PRECAUTIONS IMPORTANTES POUR VOTRE SECURITE

## CONSIGNES DE SÉCURITÉ

CETTE ALIMENTATION GÉNÈRE DES TENSIONS QUI SONT DANGEUREUSES ET PEUVENT ÊTRE FATALES.  
SOYEZ EXTRÊMEMENT VIGILANTS LORSQUE VOUS UTILISEZ CET ÉQUIPEMENT.

Les alimentations haute tension doivent toujours être mises à la masse.

Ne touchez pas les connectiques sans que l'équipement soit éteint et que la capacité à la fois de la charge et de l'alimentation soient déchargées.

Prévoyez 5 minutes pour la décharge de la capacité interne de l'alimentation.

Ne vous mettez pas à la masse, ou ne travaillez pas sous conditions mouillées ou humides.

## CONSIGNES DE SÉCURITÉ EN CAS DE REPARATION

La maintenance peut nécessiter l'enlèvement du couvercle lorsque l'alimentation est encore allumée.

Les réparations doivent être effectuées par une personne qualifiée et connaissant les risques électriques.

Dans le manuel, les notes marquées « **WARNING** » attire l'attention sur les risques lors de la manipulation de ces équipements, qui peuvent entraîner de possibles blessures voire la mort.

Dans le manuel, les notes marquées « **CAUTION** » indiquent les procédures qui doivent être suivies afin d'éviter d'éventuels dommages sur l'équipement.

## IMPORTANTI PRECAUZIONI DI SICUREZZA

### SICUREZZA

QUESTO ALIMENTATORE GENERA TENSIONI CHE SONO PERICOLOSE E POTREBBERO ESSERE MORTALI.  
PONI ESTREMA CAUTELA QUANDO OPERI CON QUESTO APPARECCHIO.

- Gli alimentatori ad alta tensione devono sempre essere collegati ad un impianto di terra.
- Non toccare le connessioni a meno che l'apparecchio sia stato spento e la capacità interna del carico e dell'alimentatore stesso siano scariche.
- Attendere cinque minuti per permettere la scarica della capacità interna dell'alimentatore ad alta tensione.
- Non mettere a terra il proprio corpo oppure operare in ambienti bagnati o saturi d'umidità.

### SICUREZZA NELLA MANUTENZIONE.

- Manutenzione potrebbe essere richiesta, rimuovendo la copertura con apparecchio acceso.
- La manutenzione deve essere svolta da personale qualificato, coscio dei rischi elettrici.
- Attenzione alle **AVVERTENZE** contenute nel manuale, che richiamano all'attenzione ai rischi quando si opera con tali unità e che potrebbero causare possibili ferite o morte.
- Le note di **CAUTELA** contenute nel manuale, indicano le procedure da seguire per evitare possibili danni all'apparecchio.

# Table of Contents

|  | PAGE |
|--|------|
| <b>1. INTRODUCTION</b>                                 |      |
| 1.1 Description Of The XRF Series .....                | 1    |
| 1.2 XRF Specifications .....                           | 1    |
| 1.3 Standard Features .....                            | 3    |
| 1.3.1 Remote Operating Features .....                  | 3    |
| 1.3.2 System Status and Fault Diagnostic Display ..... | 3    |
| 1.4 Options .....                                      | 4    |
| 1.5 Interpreting The Model Number .....                | 4    |
| <b>2. INSPECTION &amp; INSTALLATION</b>                |      |
| 2.1 Initial Inspection .....                           | 5    |
| 2.2 Mechanical Installation .....                      | 5    |
| 2.3 HV Cable Installation Instructions .....           | 5    |
| <b>3. OPERATING INSTRUCTIONS</b>                       |      |
| 3.1 Operation .....                                    | 7    |
| 3.2 Standard Features .....                            | 8    |
| <b>4. PRINCIPLES OF OPERATION</b>                      |      |
| 4.1 Chassis .....                                      | 14   |
| 4.2 Input Circuits and Power Factor Correction .....   | 14   |
| 4.3 Inverter .....                                     | 14   |
| 4.4 High Voltage Transformer .....                     | 15   |
| 4.5 High Voltage Assembly .....                        | 15   |
| 4.6 Control/Power PWB .....                            | 15   |
| 4.7 Options .....                                      | 15   |
| <b>5. OPTIONS</b>                                      |      |
| 5.1 Adjusting Overload Trip .....                      | 16   |
| 5.2 Dual Filament .....                                | 16   |
| 5.3 Grid Supply .....                                  | 16   |
| 5.4 Non-Standard Slow Start .....                      | 16   |
| 5.5 Power Control .....                                | 16   |
| 5.6 Adjustable Power Trip .....                        | 16   |
| 5.7 Arc Trip .....                                     | 16   |
| 5.8 Instant ON .....                                   | 16   |
| 5.9 Slides .....                                       | 16   |
| 5.10 Custom Designed Models .....                      | 16   |



|                             |   |
|-----------------------------|---|
| <b>6. MAINTENANCE</b>       |   |
| 6.1                         | Periodic Servicing .....17                      |
| 6.2                         | Performance Test .....17                        |
| 6.3                         | High Voltage Dividers .....17                   |
| <b>7. REPLACEMENT PARTS</b> |   |
| 7.1                         | Replacement Parts .....18                       |
| 7.2                         | Correspondence and Ordering Spare Parts .....18 |
| <b>8. FACTORY SERVICE</b>   |   |
| 8.1                         | Warranty Repairs .....19                        |
| 8.2                         | Factory Service Procedures .....19              |
| 8.3                         | Ordering Options and Modifications .....19      |
| 8.4                         | Shipping Instructions .....19                   |

## APPENDIX

- A. Specification Controls (Custom Models Only)
- B. Schematics

## LIST OF FIGURES

|             |  |
|-------------|--|
| Figure 2.1  | Dimensions XRF .....6                                    |
| Figure 3.1  | Typical Operating Setup XRF .....9                       |
| Figure 3.2A | Remote Programming Via Voltage Source .....11            |
| Figure 3.2B | Remote Programming Via External Resistance .....11       |
| Figure 3.3  | Remote Monitor Test Point Designations .....12           |
| Figure 3.4  | Remote Control of HV ON and HV OFF .....12               |
| Figure 3.5  | Remote HV ON and Remote HV OFF Indicator Circuit .....13 |
| Figure 3.6  | Remote Mode Indicators Interface .....13                 |

## LIST OF TABLES

|           |                              |
|-----------|------------------------------|
| Table 1.1 | Options .....4               |
| Table 3.1 | Rear Panel Interface .....10 |

# Chapter 1

## INTRODUCTION

### 1.1 Description Of The XRF Series

The XRF series of high voltage power supplies represent an advanced approach to X-ray generator power requirements. The XRF series provide high voltage, high current outputs with very low ripple. Extremely stable voltage and current outputs result in significant performance improvements over previously available technology. Low output ripple provides higher intensity levels, with no increase in tube loading.

All these advancements are possible only by Spellman's long history in X-ray power systems. These series of power supplies utilize extremely advanced resonant conversion techniques.

The XRF series is specifically designed for X-ray tube application where the high voltage is a negative polarity, and the filament circuits are referenced to the cathode high voltage potential, (floating filament).

The X-ray tube voltage and tube emission current are all continuously adjustable via remote controls.

The power supplies operate from a variety of line voltages and are fan cooled for 80 to 640W models, requiring no water-cooling. Custom designed units for single use or OEM applications are available.

### 1.2 XRF Specifications

- **Input Voltage:**

80W: 90-125 and 180-264Vac at 48-62Hz.  
320W: 180-264Vac at 48-62Hz.  
640W: 180-264Vac at 48-62Hz.

- **Power Factor:**

0.9 or better.

- **High Voltage Supply:**

**Output Voltage:**  
0-160kV, negative polarity.

**Output Current:**  
80W: 0.5mA max.

320W: 2.0mA at 160kV; 3.0mA at 100kV.

640W: 4.0mA.

- **Output Voltage Stability:**

80W: Within 0.1% of set value after warm-up period at full load.

320W: Within 0.1% of set value after warm-up period with load of 0-1.0mA.

640W: Within 0.1% of set value after warm-up period at full load.

- **Output Voltage Ripple:**

80W & 320W: <0.1%, or 160V p-p high freq. And line freq. at full load.

640W: 0.3%rms <1kHz, 0.75% rms above 1kHz.

- **Beam Current Stability:**

80W: Within 0.1% of set value after 30 min. period at constant output setting of 30-160IV and line voltage of 90-125 & 180-264Vac.

320W & 640W: Same as 80W except line voltage of 180-264Vac.

- **Filament Supply:** Constant current AC filament supply with closed-loop current feedback.

**Filament Voltage:** 7Vac rms (high Frequency) max.

**Filament Current:** 5A rms max., adjustable 0-0.5A by external Filament Limit Programming input.

- **Floating Grid Power Supply:**

**Grid Supply:** The grid supply controls tube beam current in a closed-loop regulation design.

**Grid Voltage:** 0-2000Vdc.

**Grid Voltage Ripple:** Less than 1.0V rms at any frequency.

**Grid Supply Response:** Less than 0.5mA in less than 10ms

- **Control and Monitoring:**

**Analog Control Inputs:** Three inputs have internal load resistance greater than 330k ohms.

**Voltage Programming:**

80W & 640W: 0 to +10Vdc, where 10.0Vdc = 160kV output. Over voltage shutdown will occur at 160kV (-0%, +5%).

320W: 0 to +10Vdc, where 8.0Vdc = 160kV output. Over voltage shutdown will occur at 160kV (-0%, +5%).

**Beam Current Control:**

80W: 0 to +10Vdc, where 10.0Vdc = 0.5mA tube current.

320W: 0 to +6Vdc, where 6.0Vdc = 3.0mA tube current.

640W: 0 to +10Vdc, where 10.0Vdc = 4.0mA tube current.

**Filament Current Control:**

0 to +10Vdc, where 5.0Vdc = 5.0 rms filament.

**Analog Monitor Outputs:** (See tables for details)

80W, 320W, 640W: High Voltage and Beam Current Monitoring

80W: Filament Current Monitoring.

320W & 640W: Internal filament current monitor test point not connected to the interface connector.

**Digital Control Inputs:** (See tables for details)  
80W, 320W, 640W: Interlock Enable.  
80W, 320W, 640W: HV Enable.  
80W: Grid Inhibit.  
640W: Filament Select.

**Digital Outputs:** (See tables for details)  
HV ON.  
Voltage Mode.  
Current Mode.

- **Connections:**

**Output Connector:** 160kV European Conical connector with 2-ring and center pin end.

**Input Power Connector:** 5-pin male MS-type, Amphenol P/N 97-3102A-18-20P.

**Control Connections:** 25-conductor "D" connector, male, chassis mounted. (JB1 and TB1).

- **Environmental:**

0 to +50° at 10-95% RH, non-condensing.  
Forced Convection Cooling

- **Dimensions:**

7"H x 19"W x 22"D. (17.8cm x 48.3cm x 55.9cm).

- **Physical:**

Enclosed, aluminum chassis.

## 1.3 Standard Features

The XRF series incorporates several standard features designed to optimize user satisfaction and safety.

**KV AND MA/FILAMENT CURRENT RAMP CIRCUITS:** This feature provides for a gradual rise for kV, mA and filament current. This feature is designed to limit voltage shock and filament shock to the X-ray tube. The kV ramp rate is approximately 1 second. The filament current is slowly increased until the desired mA level is achieved. This time is typically 1 second for full mA output. These ramp conditions are started at the initial HV ON control signal.

**ARC DETECT / ARC QUENCH / ARC COUNT:** These features allow the user to tailor the power supply to meet specific needs in dynamic load applications. If an arc occurs, the output is inhibited for approximately one second, then the output is ramped up to the preset level with the Slow-start circuitry. See Chapter 3 for operating details and information for user customization for these features.

**INTERNAL FAULT PROTECTION:** The XRF series continually monitors internal circuits critical to the proper operation of the power supply. In the event that one of these circuits does not function correctly, the fault detection circuit latches the appropriate fault on the front panel display and turns off the outputs and reverts the unit to the POWER DOWN mode.

**INDICATOR LAMPS:** HIGH VOLTAGE OFF and HIGH VOLTAGE ON indicators.

### 1.3.1 Remote Operating Features

**REMOTE PROGRAMMING:** Allows remote adjustment of the output voltage and current via an external voltage source. The output power is also remotely controllable when the CPC or APT option is ordered.

**REMOTE MONITOR:** Allows remote monitoring of the tube voltage and tube emission current. NOTE: Output power remote monitor is included with the CPC and APT options.

**REMOTE HIGH VOLTAGE CONTROL:** Allows remote control of the HIGH VOLTAGE ON and HIGH VOLTAGE OFF functions. Signals are also provided for remote indication of HV ON or HV OFF status.

**EXTERNAL INHIBIT:** A circuit that will inhibit the high voltage output is provided of the 25 pin mini-D connector on the rear of the chassis. A logic low, ground, will inhibit the high voltage output and a logic high, open,

will restore the high voltage output to the preset level.

NOTE: The External Inhibit circuit should NOT be used for protection against injury or for safety interlock. See External Interlock for this type of safety control

**EXTERNAL INTERLOCK:** Interlock connections are provided on the terminal block on the rear of the chassis for connection to a safety switch. The unit will not operate unless the interlock circuit is closed. During high voltage operation, opening the interlock circuit will cause the High Voltage to shut off. This circuit should be used for safety interlock circuits.

### 1.3.2 System Status and Fault Diagnostic Display

“Dead Front” type indicators are provided to give the user complete indication of system operation and fault conditions. If a fault occurs the power supply will revert to the POWER DOWN mode. This is indicated by both the HV ON and HV OFF lamps turning off. To reset, depress the HV OFF switch.

**VOLTAGE (CONTROL):** Indicates the output voltage regulator circuit is maintaining voltage regulation.

**CURRENT (CONTROL):** Indicates the output current regulator circuit is regulating tube current.

**POWER (CONTROL):** Indicates the output power regulator circuit is regulating tube power (optional).

**INTLK CLSD:** Indicates the EXTERNAL INTERLOCK connections are in the closed position. This also indicates closure of internal power supply interlocks.

**INTLK OPEN:** Indicates the EXTERNAL INTERLOCK connections are in the open position. This also indicates opening of internal power supply interlocks.

**INTLK INHIBIT:** Indicates that the high voltage supply is being inhibited by either the EXTERNAL INHIBIT or internal protection circuitry.

**OVERVOLT:** Indicates the overvoltage protection circuitry has caused the power supply to turn off. Overvoltage protection is internally set to 110% of rated output voltage.

**OVERCURR:** Indicates the output current has exceeded the programmed current trip level when the AOL (Adjustable Overload Trip) or the OL (Overload Trip) options are installed.

**OVERPWR:** Indicates the output power has exceeded the internally set level or the remote programmed level if the optional circuitry is installed.

**RGLT ERR:** Indicates a failure in the voltage, current or power regulation circuitry. This fault usually occurs when there is a lack of output power to maintain regulation.

**ARC:** Indicates that an arc has occurred within the previous one second or that the ARC COUNT/TRIP has shutdown the power supply.

**OVR TEMP:** Indicates that the inverter for the high voltage power supply is running hot.

## 1.4 Options

| CODE DISCRIPTION |                                   |
|------------------|-----------------------------------|
| • <b>AOL</b>     | Adjustable Overload Trip (0-103%) |
| • <b>DF</b>      | Dual Frequency                    |
| • <b>GS</b>      | Grid Supply                       |
| • <b>SS(X)</b>   | Non-Standard Slow Start           |
| • <b>APT</b>     | Adjustable Power Trip             |
| • <b>AT</b>      | Arc Trip                          |
| • <b>IO</b>      | Instant On                        |
| • <b>SL</b>      | Slides                            |

**Table 1.1 XRF Options**

The options available are listed in Table 1.1. See Section 5 for more information on these options along with operating and set-up instructions. With few exceptions, these options and modifications can be retrofitted to your power supply at the factory in a short time. For price and retrofit arrangements, contact Spellman's Sales Department.

## 1.5 Interpreting the Model Number:

The model number of the power supply describes its capabilities. After the series name is:

- (1) the maximum voltage (in kV)
- (2) the maximum output (in watts)
- (3) the option codes for all options that are included.

Custom units have an X number after the option codes.

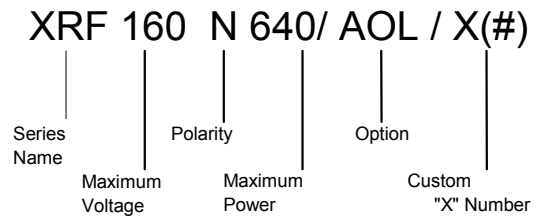

# Chapter 2

## Inspection and Installation

Initial inspection and preliminary checkout procedures are recommended. For safe operation, please follow the step-by-step procedures described in Chapter 3, Operating Instructions.

### 2.1 Initial Inspection

Inspect the package exterior for evidence of damage due to handling in transit. Notify the carrier and Spellman immediately if damage is evident. Do not destroy or remove any of the packing material used in a damaged shipment.

After unpacking, inspect the panel and chassis for visible damage.

Fill out and mail the Warranty Registration card accompanying the unit. Standard Spellman XRF high voltage power supplies and components are covered by warranty. Custom and special order models (with an X suffix in the model number) are also covered by warranty.

### 2.2 Mechanical Installation

Units in the XRF series have front panel holes for standard EIA rack mounting. The rack must allow rear access for cable connections. Units are fully enclosed and are suitable for bench or tabletop operation. Standard unit dimensions are shown in Figure 2.1. It is strongly recommended to support the chassis by guides or slides. Slides are available for ease of servicing. (See Chapter 5 for Slides (SL) option).

Figure 2.1 XRF dimensions drawings are on the following page.

Note: This power supply uses a high voltage connector that depends on the following procedure for safe and reliable operation. This

procedure must be followed every time the connector is inserted.

### 2.3 H.V. Cable Installation Instructions

1. Remove old grease from female connector socket and from rubber cable plug using lint free cloth or Kimwipe. A small quantity of fresh grease on cloth or Kimwipe may be used to soften and permit removal of old grease.

2. Loosen set screws on cable flange so flange is free to turn.

3. Apply fresh grease directly to entire rubber surface on the cable plug using a clean finger to spread it evenly. Do not grease the contact at the end of the cable. Spread grease from contact end to flange end.

4. Insert rubber cable end firmly into female socket using moderate pressure to insure accurate measurement. Adjust cable flange by rotating so that a 4.0-4.5mm gap exists between cable flange and mating surface of female socket with cable plug firmly inserted into socket. When adjustment is complete, tighten set screws to lock flange into cable.

5. Tighten all four socket head screws drawing the cable flange completely into contact with the mating surface of the female socket.

6. Repeat steps 1 through 5 for the other end of the cable.

7. This procedure should be followed whenever the cable end is removed from socket.

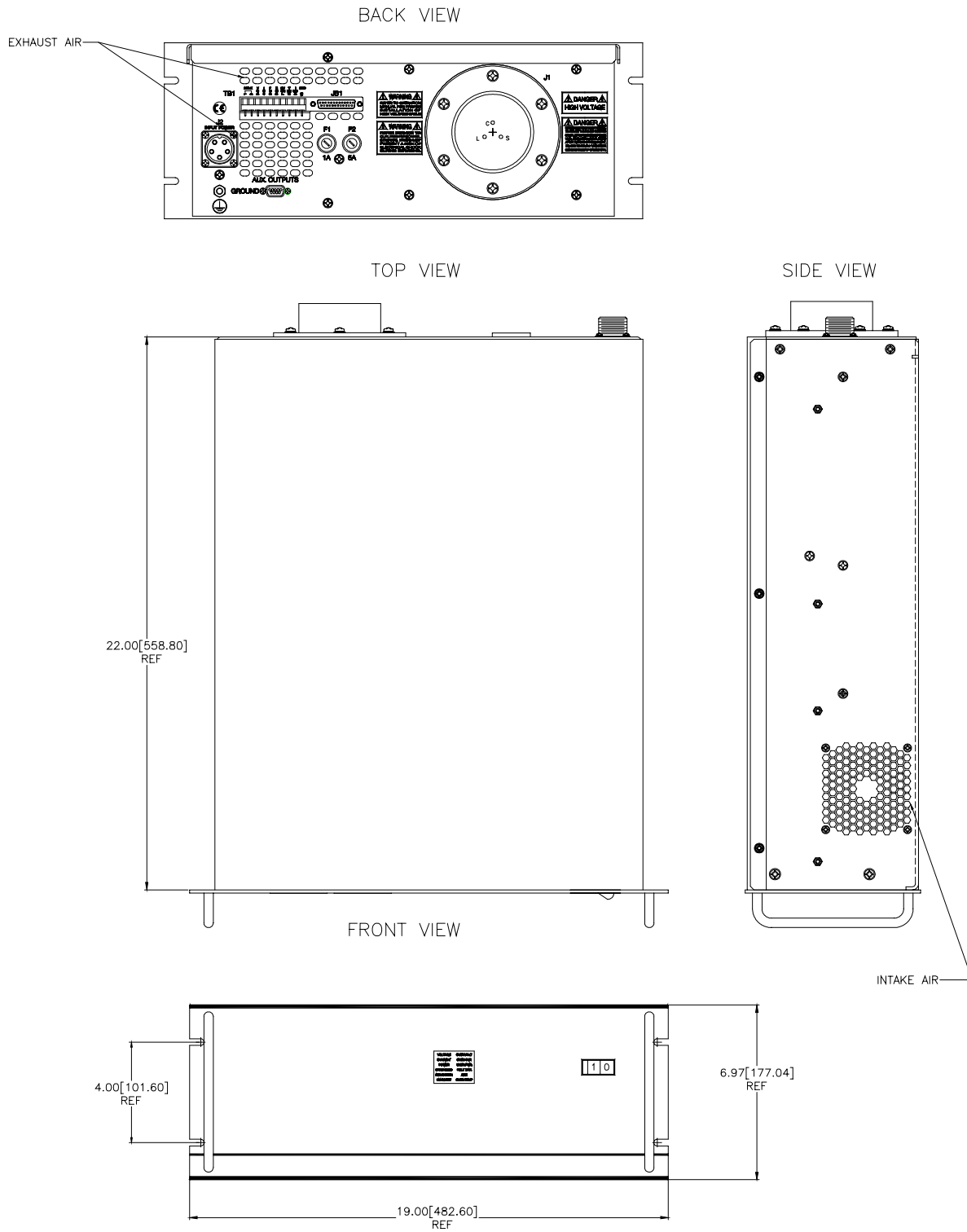

**Figure 2.1 XRF DIMENSIONS**

# Chapter 3

## Operating Instructions

### 3.1 Operation

#### WARNING

**THIS EQUIPMENT GENERATES  
DANGEROUS VOLTAGES THAT MAY BE  
FATAL.  
PROPER GROUNDING OF ALL HIGH  
VOLTAGE EQUIPMENT IS ESSENTIAL.**

#### WARNING:

**Before connecting the power supply to the  
AC line, follow this step-by-step procedure.  
Do not connect the power supply to the AC  
line until Step G is reached.  
Failure to follow these procedures may void  
the warranty.**

A) Insure that the Circuit Breaker is in the OFF position (0).

B) Check the input voltage rating on the nameplate of the supply and make certain that this is the rating of the available power source. Spellman XRF units operate on 90-264VAC , 48-62Hz depending on model.

C) **PROPER GROUNDING TECHNIQUE:** The chassis of high voltage power supplies must be grounded, preferably to a water system ground using copper pipe or other earth ground using the connection terminal at the rear of the unit. See Figure 3.1, for a typical operating setup.

The return line from the load should be connected to the terminal on the rear of the power supply. Using a separate external ground at the load is not recommended.

D) Attach the output cable to the X-ray tube. The same procedure as for the power supply end should be used.

E) **Options Note:** See section 5 for hook up and operating instructions for the options on your unit. Custom models may also require set up changes.

F) For initial turn-on, start the voltage control at the zero voltage position. The HV ON control should be low to begin.

G) The input power cable may now be connected to the AC power line.

H) Switch the front panel circuit breaker to the ON position (1). (If the supply is to be turned off for an extended period of time the line cord should be disconnected). The unit is now in the HIGH VOLTAGE OFF mode. The HIGH VOLTAGE INHIBIT light should be lit.

NOTE: No actual output is being produced at this stage.

I) Bring the HV ON signal high, the HV INHIBIT light will go out and the 'Voltage' light will light up and the output will slow start to the preset level output voltage and/or output current.

**Note:** The XRF series is equipped with a slow start circuit that ramps the output up to its maximum setting in approximately 1 second after the HIGH VOLTAGE ON command is given.

J) To terminate the generation of output power, bring the HV ON signal low. In the HIGH VOLTAGE INHIBIT mode the power supply's fault and interface circuits are still active..

K) To turn off the power supply, turn the circuit breaker to the off position (0).

NOTE: If a power supply fault, or system monitoring fault occurs, the power supply will revert to the POWER DOWN mode. In this mode the output power will be turned off. The HV INHIBIT lamp will be on. To reset, toggle the input power.



## WARNING

**AFTER TURNOFF, DO NOT HANDLE THE LOAD UNTIL THE CAPACITANCE HAS BEEN DISCHARGED!  
LOAD CAPACITANCE MAY BE DISCHARGED BY SHORTING TO GROUND.**

## CAUTION

**ALWAYS OPERATE THE UNIT WITH THE COVER ON.**

A fan maintains safe operating temperature in the XRF power supplies by drawing air over the circuit components. The cover must be on in order to direct the air flow over the areas that need cooling. In operation, the unit must be placed so that the air intake and the fan exhaust are clear of any obstructions that might impede the flow of air.

### 3.2 Standard Features

A note on remote interface circuitry and remote signal grounding. Whenever possible, electrical isolation should be provided when interfacing with any high voltage power supply. For power control signals such as EXTERNAL INTERLOCK, HIGH VOLTAGE OFF and HIGH VOLTAGE ON isolated relay contacts should be used. For status signals and control signals such as HIGH VOLTAGE ON, HIGH VOLTAGE OFF, EXTERNAL INHIBIT, etc. opto-isolation should be used. If possible, analog programming and monitoring signals should be isolated via analog isolation amplifiers. Spellman application engineers are available to assist in interface circuitry design. All interface cables should be properly shielded. All power supply signals should be referenced to the power supplies signal ground on the rear terminal block.

**REMOTE PROGRAMMING:** Allows remote adjustment of the output voltage and current via an external voltage source. (Output power is also remotely controllable with the CPC and APT options).

For remote programming, the jumpers are removed and a positive voltage source, from 0 to 10 volts, is applied to the appropriate terminals. Programming signals should be referenced to signal ground. By adjusting the voltage source from 0 volts (zero output) to 10 volts (full rated output) the desired output can be selected. See Figure 3.2A for wiring diagram and specifications.

An alternate method of controlling the output remotely is by using external resistance such as a potentiometer or a resistor network. For remote control the jumpers are removed and the desired resistor configuration is installed. See Figure 3.2B for wiring diagram.

**REMOTE MONITOR:** Test points are made available at the terminal block on the rear of the chassis for monitoring the voltage and current output. (Output power monitor is included with the CPC and APT option). The test points are always positive regardless of the output polarity, where zero to 10 volts equals 0-100% of output  $\pm 0.5\%$ . Test points have an output impedance of 220 ohms. See Figure 3.3 for test point designation.

**REMOTE CONTROL:** Remote control of the POWER ON, HIGH VOLTAGE ON and HIGH VOLTAGE OFF can be accomplished via the rear panel interface. See Figure 3.4 for recommended interface.

## WARNING

**It is extremely dangerous to use this Inhibit circuit to inhibit high voltage generation for the purpose of servicing or approaching any area of load considered unsafe during normal use.**

**EXTERNAL INTERLOCK:** Interlock connections are provided on the terminal on the rear of the chassis for connection to a safety switch. The unit will not operate unless the interlock circuit is closed. If the interlock is not being used, the jumper installed on the terminals before shipping *must* be in place. If the jumper is missing, or there is an open between the interlock terminals the unit's high voltage inverter will be disabled. During high voltage operation, opening the interlock circuit will cause the unit to revert to the HIGH VOLTAGE OFF mode. Subsequent closing of the interlock circuit will NOT return the unit to HIGH VOLTAGE ON mode. See Figure 3.5 for the recommended interface circuit.

**ARC DETECT / ARC QUENCH / ARC COUNT:** The ARC DETECT circuit senses dynamic arcing or discharge conditions present at the output load. If an arc occurs, the output is inhibited for one second. After the one-second period, the output is ramped up to the previous set level. This ramp is based on the standard one-second slow start feature. Caution should be observed if this feature is disabled. Discharge rates of greater than 1 Hz may cause excessive power dissipation in the power supply's output limiting resistors.

The ARC COUNT feature will allow the user to program the ARC fault parameters. The ARC indicator on the front panel will illuminate for approximately one second after each arc has occurred. The power supply can be programmed to trip to the POWER DOWN mode if an arc occurs. The standard feature is programmed to trip the power supply if 8 arcs occur within a twenty second period.

**REMOTE MODE INDICATORS:** Signals are provided for remote indication of the control mode status, voltage control, current control and power control. See Figure 3.6 for the recommended interface.

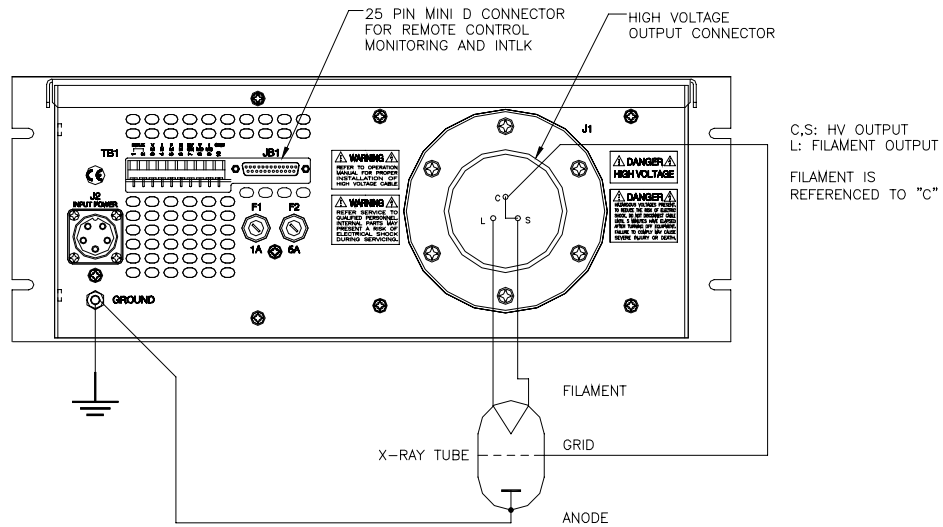

TYPICAL OPERATING SETUP/FILAMENT CONTROLLED EMISSION LOOP

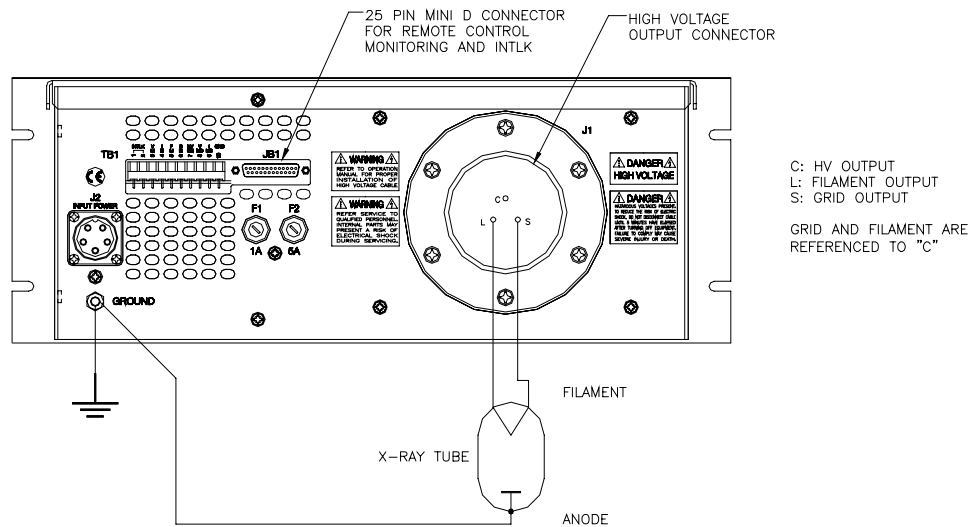

Figure 3.1 Typical Operating Setup XLG

| <b>JB1</b> | <b>SIGNAL</b>             | <b>SIGNAL PARAMETERS</b>                   |
|------------|---------------------------|--|
| 1          | Filament Limit            | 0-5V = 5-5A Filament Limit                 |
| 2          | High Voltage On Control   | +12VDC IN = HV ON                          |
| 3          | N/U                       |  |
| 4          | N/U                       |  |
| 5          | High Voltage On Status    | Open = HV ON for 320W, Low = HV ON for 80W |
| 6          | A-Ground                  | Analog Signal Ground                       |
| 7          | kV Monitor                | 0-10V = 0-160kV                            |
| 8          | Interlock Control         | +12VDC IN = Interlock Closed               |
| 9          | N/U                       |  |
| 10         | mA Demand                 | 0-10V = 0 to Full Output Current           |
| 11         | N/U                       |  |
| 12         | N/U                       |  |
| 13         | D-Ground                  | Digital Ground                             |
| 14         | Fil. Monitor              | 0-5V = 0-5A rms                            |
| 15         | N/U                       |  |
| 16         | N/U                       |  |
| 17         | N/U                       |  |
| 18         | N/U                       |  |
| 19         | mA Monitor                | 0-10V = 0 to Full Current                  |
| 20         | N/U                       |  |
| 21         | +12VDC Out                |  |
| 22         | kV Demand                 | 0-10V                                      |
| 23         | Grid Inhibit              | (Low = Grid Inhibit)                       |
| 24         | N/U                       |  |
| 25         | Chassis Gnd. (I/O Shield) | Chassis Gnd.                               |

| <b>TB1</b> | <b>SIGNAL</b>          | <b>SIGNAL PARAMETERS</b>         |
|------------|------------------------|----------------------------------|
| 1          | Interlock              | Jumper to TB2 to close interlock |
| 2          | Interlock Return       |                                  |
| 3          | kV Monitor             | 0-10V = 0-160kV                  |
| 4          | mA Monitor             | 0-10V = 0 to Full Current        |
| 5          | Filament Monitor       | 0-5V = 0-5A rms                  |
| 6          | Bias Monitor           | 1V = 1000V                       |
| 7          | HV ON Indicator        | +15V = HV ON                     |
| 8          | Voltage Mode Indicator | Low = Voltage Mode               |
| 9          | Current Mode Indicator | Low = Current Mode               |
| 10         | GND                    | Ground                           |

**Table 3.1 Rear Panel Interface**

JB1

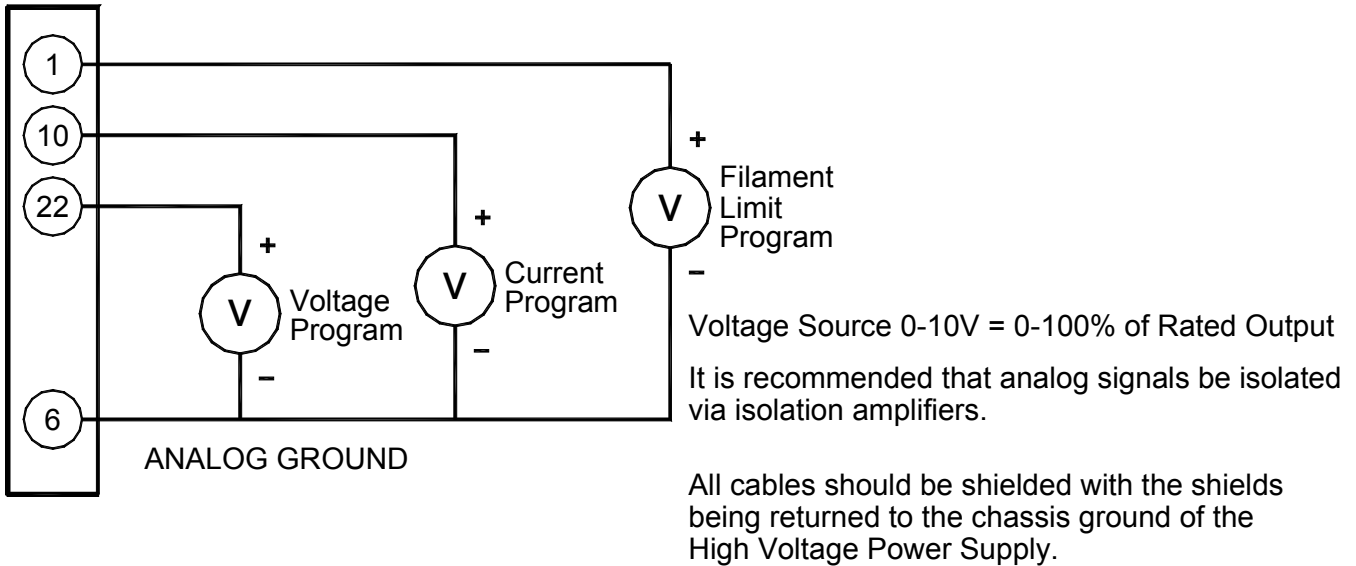

Figure 3.2A Wiring Diagram for Programming Via Voltage Source

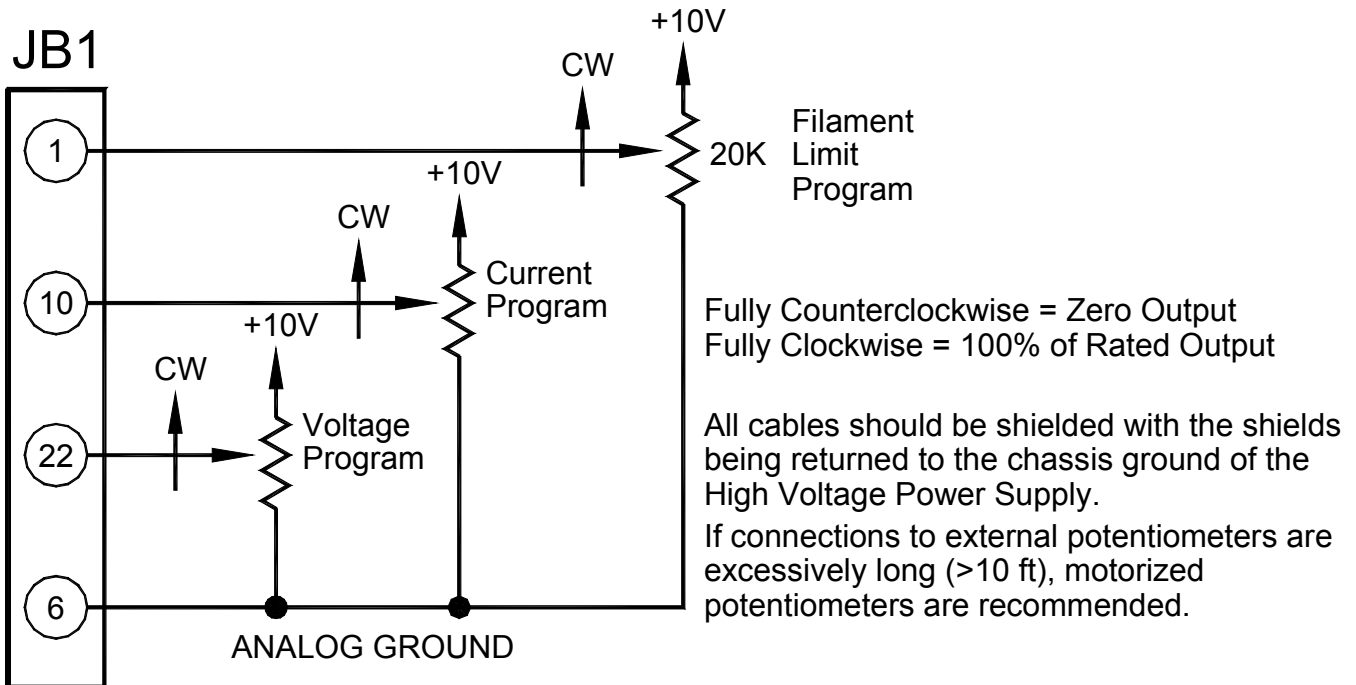
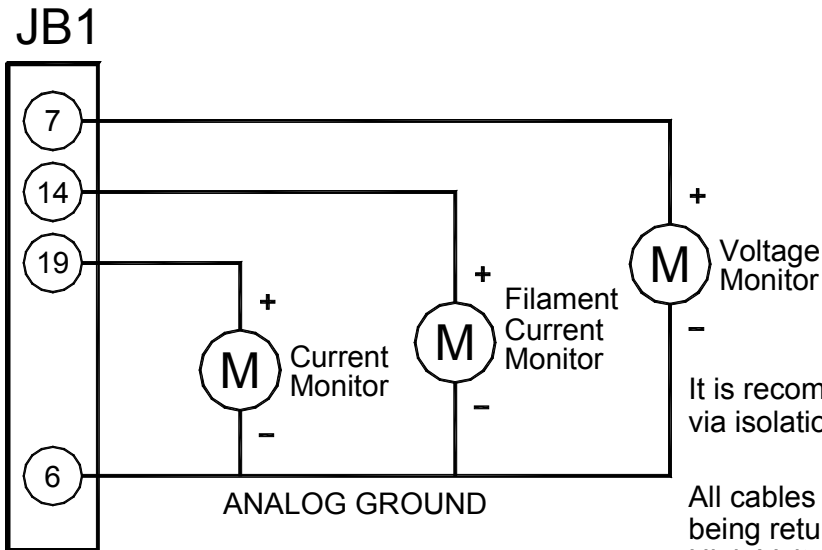

Figure 3.2B Wiring Diagram for Programming Via External Resistance



It is recommended that analog signals be isolated via isolation amplifiers.

All cables should be shielded with the shields being returned to the chassis ground of the High Voltage Power Supply.

Figure 3.3 Monitor Test Point Designations

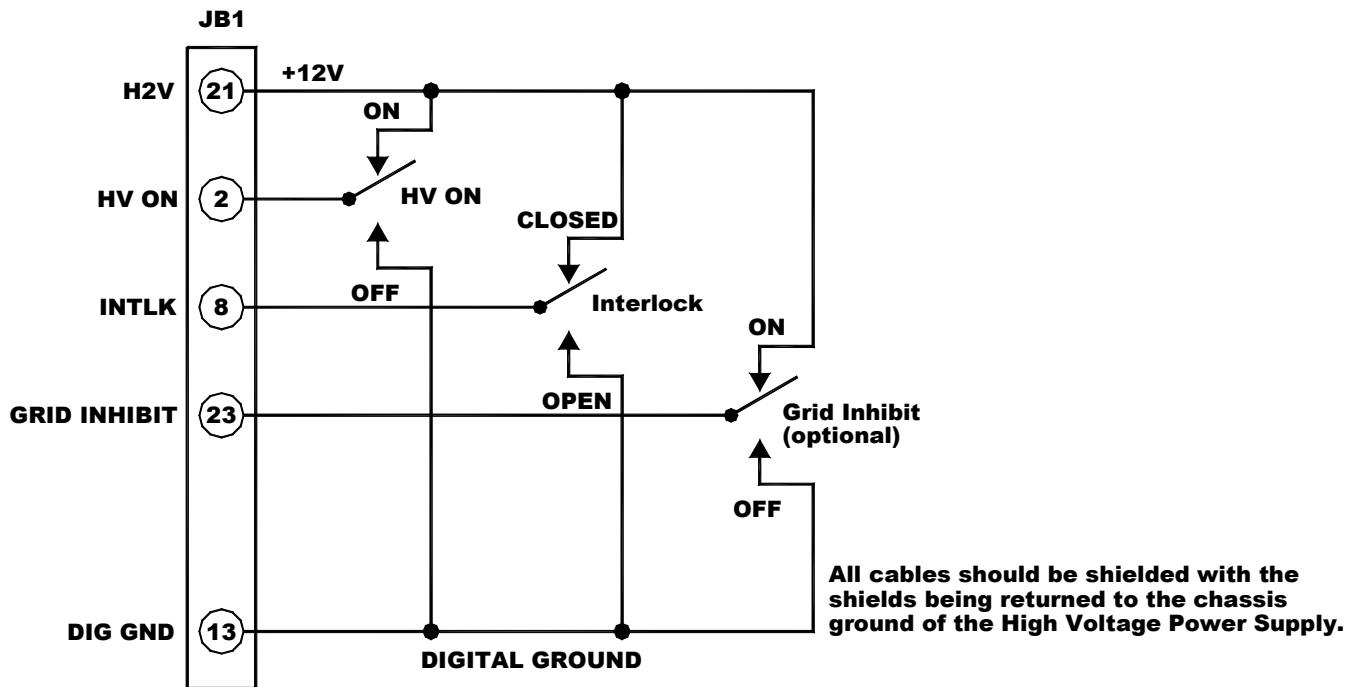

All cables should be shielded with the shields being returned to the chassis ground of the High Voltage Power Supply.

Figure 3.4 Control of HV ON, Interlock and Grid ON

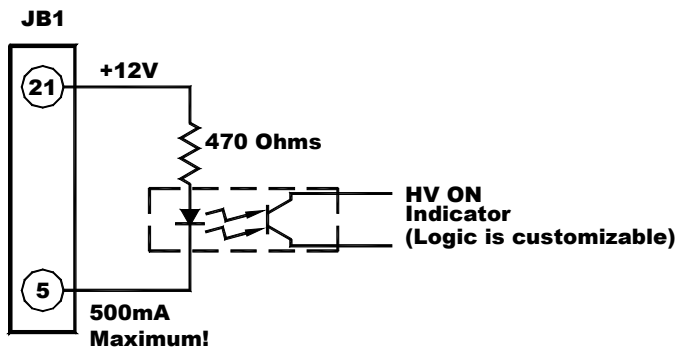

12dc lamps or relay coils may replace opto-couplers. Opto-couplers, lamps or relays should be located as close as possible to the high voltage power supply. All cables should be shielded with the shields being returned to chassis ground of the High Voltage Power Supply.

Figure 3.5 Remote High Voltage ON Indicator

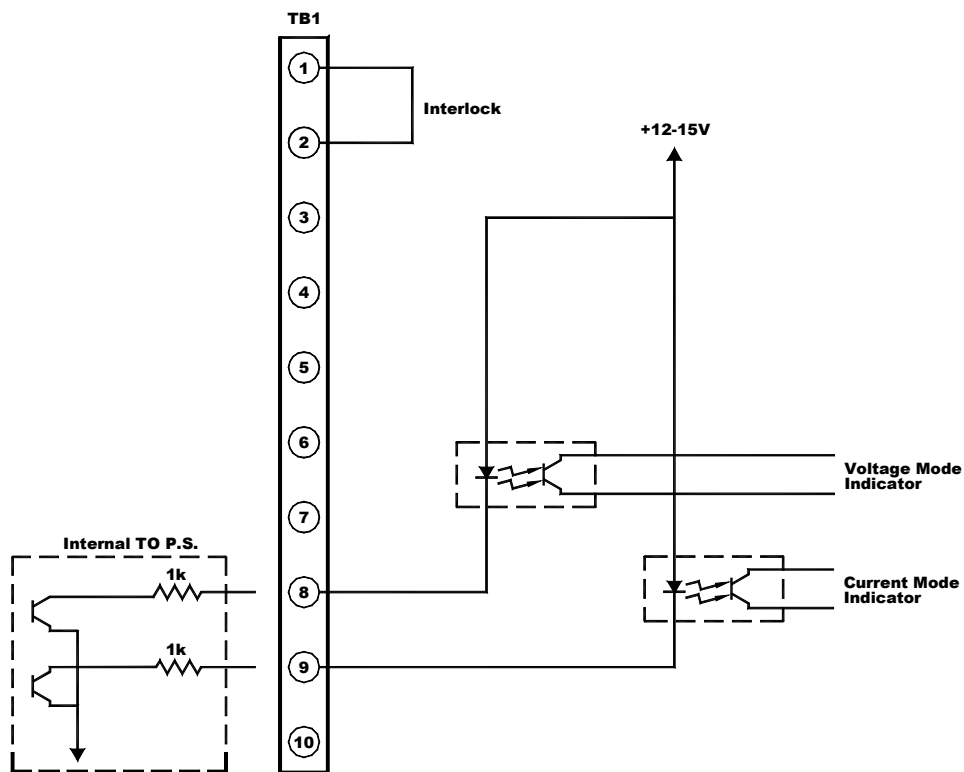

Figure 3.6 Remote Indicator Interface

The ten position terminal block has some functions duplicated from the 25 pin interface connector. The mode indicators are unique to TB1 and are the only connections shown for that reason.

The interlock on TB1-1 and TB1-2 is in series with the interlock on JB-1 and must be closed for the unit to operate.

# Chapter 4

## Principles of Operation

The XRF series of high voltage power supplies utilizes sophisticated power conversion technology. A variety of analog, digital and power conversion techniques are used throughout. The intention of the Principles of Operation is to introduce the basic function blocks that comprise the XRF power supply. For details on a specific circuit, consult Spellman's Engineering Department.

The XRF power supply is basically an AC to DC converter. Within the power supply, conversions of AC to DC, then high frequency AC, then to high voltage DC take place. By reviewing further the sub-assemblies, a basic understanding of the process can be gained.

### 4.1 Chassis

The XRF is a compact, high efficiency, high voltage power supply. The power supply can supply up to 640 watts of DC power. (Output power capability may be higher or lower depending upon model ordered). Output voltages of up to 160kV can be generated.

#### WARNING

The energy levels used and generated by the power supply can be lethal! Do not attempt to operate the power supply unless the user has a sufficient knowledge of the dangers and hazards of working with high voltage. Do not attempt to approach or touch any internal or external circuits or components that are connected or have been connected to the power supply. Be certain to discharge any stored energy that may be present before and after the power supply is used. Consult IEEE recommended practices for safety in high voltage testing #510-1983.

### 4.2 Input Circuits and Power Factor Correction

The XRF series can operate from 90Vac to 264Vac at 48-62Hz input depending on the model. An internal EMI filter on each of the inputs provides filtering to minimize noise put back on the line

The main input is power factor corrected. The AC line is rectified and converted to a regulated +400Vdc, which supplies power to the HV power supply and filament power supply. This process controls the input current wave form to be a sinusoid in phase with the input voltage, achieving power factors greater than 0.9.

The AUX input provides all the 'housekeeping' voltages to run the control circuitry.

#### WARNING

**LINE VOLTAGE IS PRESENT WHENEVER THE POWER SUPPLY IS CONNECTED TO EXTERNAL LINE VOLTAGES. BE SURE TO DISCONNECT THE LINE CORD BEFORE OPENING THE UNIT. ALLOW 5 MINUTES FOR INTERNAL CAPACITANCE TO DISCHARGE BEFORE REMOVING ANY COVER.**

### 4.3 Inverter

The inverter is a series resonant, parallel loaded topology. A pulse width modulated control scheme is used for regulating the power generated from the inverter. Q2, Q3, Q4, and Q5 are high speed MOSFET's. These devices provide high frequency switching to control the resonant current flow. The gate control for the switching devices is provided by T2 on the CONTROL/POWER PWB. U23 and U24 provide the gates high current pulse requirements. T2 provides line voltage isolation.

## 4.4 High Voltage Transformer

The output of the High Frequency Resonant Inverter is connected to the primary of the High Voltage Transformer. The High Voltage Transformer is a step-up type. Typically secondary voltages are in the range of 8kV to 10kV depending upon output voltage ratings.

## 4.5 High Voltage Assembly

The High Voltage Assembly will vary depending upon the model ordered. The circuitry typically consists of series arrangements of a full wave voltage doubler.

Voltage feedback for regulation and monitoring is provided by a high bandwidth resistive/capacitive divider. Current feedback for regulation and monitoring is provided by a sense resistor connected at the low voltage end of the High Voltage Rectifier/Multiplier Circuit.

## 4.6 Control/Power PWB

The control circuits for power supply controls are located on the CONTROL/POWER PWB. The CONTROL/POWER PWB controls all functions of producing the HV and Filament Drive as well as the optional grid circuitry. It also controls the monitor outputs and interlock circuits. Control circuits are used for regulation, monitoring, pulse-width control, slow-start and inhibit control. Feedback signals are calibrated and buffered via general purpose OP-AMPS. Pulse width control is accomplished by a typical PWM type control I.C. Logic enable/disable is provided by a logic gate I.C.

## 4.7 Options

Due to the many variations of models and options provided in the XRF series, details of actual circuits used may differ slightly from above descriptions. Consult Spellman's Engineering Department for questions regarding the principles of operations for the XRF series.



# Chapter 5

## OPTIONS

The options available for this power supply are described in this section. Interface diagrams are shown where required. Options are specified by including the option code in the model number as described in Section 1.5.

### 5.1 Adjustable Overload Trip

**AOL**

The overload trip protection feature rapidly shuts down the high voltage output when the load current exceeds the limit set. A fast acting circuit inhibits the generation of high voltage and reverts the unit to POWER DOWN mode, illuminating the OVER CURRENT indicator. When adjustable overload trip is provided, it replaces the standard current regulation feature.

### 5.2 Dual Filament

**DF**

Provisions are available to implement two filament outputs for large/small focal spot switching. Specify at time of order.

### 5.3 Grid Supply

**GS**

An optional floating grid supply is available. Typical application calls for -1200Vdc referenced to the HV output. Custom grid voltages are available. In many applications that call for a grid supply the emission loop is controlled by the grid voltage.

### 5.4 Non-Standard Slow Start

**SS(x)**

The non-standard slow start option allows the gradual rise time of the output voltage to be different from the standard of six seconds. To order the option, place the time desired in seconds after the suffix letter; i.e. SS(10) denotes a 10 second rise time.

### 5.5 Power Control

**PC**

A power programming input can provide an actual output power control. A 0-10V signal will program the supply for 0-100% output power.

### 5.6 Adjustable Power Trip

**APT**

The power control options allow monitoring and control of the power supply output power. The APT option allows the user to remotely adjust the power limit for the power supply. If the power limit is exceeded, the unit will shut down with an OVERPOWER fault.

### 5.7 Arc Trip Option

**AT**

When this option is ordered, the ARC Count circuit is set so the unit trips to Standby after 1 count. One of the applications for this option is for sensing material breakdown under an applied high voltage.

### 5.8 Instant On

**IO**

When the Instant On option is ordered, the High Voltage is enabled as soon as line voltage is applied when the circuit breaker is in the ON position. To enable Instant ON, keep the HV ON switch in the ON position.

#### CAUTION

**The Power Supply will generate programmed High Voltage whenever the circuit breaker is in the ON position, and line voltage is applied.**

### 5.9 Slides

**SL**

Slides or guides can be mounted to ease removal or servicing of the chassis when mounted in a rack.

### 5.10 Custom Designed Models

**X(#)**

Units built to customer specifications are assigned an X number by the factory. If this unit is an X model, specification control sheet is added at the end of this instruction manual.

Spellman welcomes the opportunity to tailor units to fit your requirements or to develop new products for your applications. Contact Spellman Sales Department with your needs.

# Chapter 6

## MAINTENANCE

This section describes periodic servicing and performance testing procedures.

### WARNING

**THIS POWER SUPPLY GENERATES VOLTAGES THAT ARE DANGEROUS AND MAY BE FATAL. OBSERVE EXTREME CAUTION WHEN WORKING WITH HIGH VOLTAGE.**

### 6.1 Periodic Servicing

Approximately once a year (more often in high dust environments), disconnect the power to the unit and remove the top cover. Use compressed air to blow dust out of the inside of the unit. Avoid touching or handling the high voltage assembly. Be sure that the fan is not obstructed and spins freely. The fan has sealed bearings and does not need lubrication. Be sure to replace the top cover before operating for proper cooling.

### 6.2 Performance Test

#### WARNING

**HIGH VOLTAGE IS DANGEROUS.**

**ONLY QUALIFIED PERSONNEL SHOULD PERFORM THESE TESTS.**

High voltage test procedures are described in Bulletin STP-783, Standard Test Procedures for High Voltage Power Supplies. Copies can be obtained from the Spellman Customer Service Department. Test equipment, including an oscilloscope, a high impedance voltmeter, and a high voltage divider such as the Spellman HVD-100 or HVD-200, is needed for performance tests. All test components must be rated for operating voltage.

### 6.3 High Voltage Dividers

High voltage dividers for precise measurements of output voltage with an accuracy up to 0.1% are available from Spellman. The HVD-100 is used for voltages up to 100KV. The HVD-200 measures up to 200KV. The Spellman divider is designed for use with differential voltmeters or high impedance digital voltmeters. The high input impedance is ideal for measuring high voltage low current sources, which would be overloaded by traditional lower impedance dividers.

# Chapter 7

## REPLACEMENT PARTS

### 7.1 Replacement Parts

Contact the Spellman Customer Service Department for parts lists for specific models.

Spellman provides parts and subassemblies for its high voltage power supplies but recommends that only qualified personnel perform the repair. High voltage is dangerous; even minor mistakes in repairs can have serious consequences.

When requesting parts please give the model number and serial number of the power supply

### 7.2 Correspondence And Ordering Spare Parts

Each Spellman power supply has an identification label on the rear of the chassis that bears its model and serial number.

When requesting engineering or applications information, please state the model and serial number of the power supply. If specific components or circuit sections are involved in the inquiry, it is helpful to indicate the component symbol number(s) shown on the applicable schematic diagram.

When ordering spare parts, please specify the part's description, the part's reference designation or part number, and the model and serial number of the unit.

# Chapter 8

## FACTORY SERVICE

### 8.1 Warranty Repairs

During the Warranty period, Spellman will repair all units free of charge. The Warranty is void if the unit is worked on by other than Spellman personnel. See the Warranty in the rear of this manual for more information. Follow the return procedures described in Section 8.2. The customer shall pay for shipping to and from Spellman.

### 8.2 Factory Service Procedures

Spellman has a well-equipped factory repair department. If a unit is returned to the factory for calibration or repair, a detailed description of the specific problem should be attached.

For all units returned for repair, please obtain an authorization to ship from the Customer Service Department, either by phone or mail prior to shipping. When you call, please state the model and serial numbers, which are on the plate on the rear of the power supply, and the purchase order number for the repair. A Return Material Authorization Code Number (RMA Number) is needed for all returns. This RMA Number should be marked clearly on the outside of the shipping container. Packages received without an RMA Number will be returned to the customer. The Customer shall pay for shipping to and from Spellman.

A preliminary estimate for repairs will be given by phone by Customer Service. A purchase order for this amount is requested upon issuance of the RMA Number. A more detailed estimate will be made when the power supply is received at the Spellman Repair Center. In the event that repair work is extensive, Spellman will call to seek additional authorization from your company before completing the repairs.

### 8.3 Ordering Options And Modifications

Many of the options listed in Chapter 5 can be retrofitted into Spellman power supplies by our factory. For prices and arrangements, contact our Sales Department.

### 8.4 Shipping Instructions

All power supplies returned to Spellman must be sent shipping prepaid. Pack the units carefully and securely in a suitable container, preferably in the original container, if available. The power supply should be surrounded by at least four inches of shock absorbing material. Please return all associated materials, i.e. high voltage output cables, interconnection cables, etc., so that we can examine and test the entire system.

All correspondence and phone calls should be directed to:

**Spellman High Voltage Electronics Corp.**  
475 Wireless Boulevard  
Hauppauge, New York 11788  
TEL: (631) 630-3000 FAX: (631) 435-1620  
E-Mail: [sales@Spellmanhv.com](mailto:sales@Spellmanhv.com)  
<http://www.spellmanhv.com>

# SPELLMAN HIGH VOLTAGE ELECTRONICS

## WARRANTY

**Spellman** High Voltage Electronics ("**Spellman**") warrants that all power supplies it manufactures will be free from defects in materials and factory workmanship, and agrees to repair or replace, without charge, any power supply that under normal use, operating conditions and maintenance reveals during the warranty period a defect in materials or factory workmanship. The warranty period is twelve (12) months from the date of shipment of the power supply. With respect to standard SL power supplies (not customized) the warranty period is thirty-six (36) months from the date of shipment of the power supply.

This warranty does not apply to any power supply that has been:

- Disassembled, altered, tampered, repaired or worked on by persons unauthorized by **Spellman**;
- subjected to misuse, negligent handling, or accident not caused by the power supply;
- installed, connected, adjusted, or used other than in accordance with the original intended application and/or instructions furnished by **Spellman**.

THE FOREGOING WARRANTY IS IN LIEU OF ALL OTHER WARRANTIES, EXPRESS OR IMPLIED, INCLUDING THOSE OF MERCHANTABILITY OR FITNESS FOR A PARTICULAR PURPOSE.

The buyer's sole remedy for a claimed breach of this warranty, and **Spellman's** sole liability is limited, at **Spellman's** discretion, to a refund of the purchase price or the repair or replacement of the power supply at **Spellman's** cost. The buyer will be responsible for shipping charges to and from **Spellman's** plant. The buyer will not be entitled to make claim for, or recover, any anticipatory profits, or incidental, special or consequential damages resulting from, or in any way relating to, an alleged breach of this warranty.

No modification, amendment, supplement, addition, or other variation of this warranty will be binding unless it is set forth in a written instrument signed by an authorized officer of **Spellman**.

### Factory Service Procedures

For an authorization to ship contact **Spellman's** Customer Service Department. Please state the model and serial numbers, which are on the plate on the rear panel of the power supply and the reason for return. A Return Material Authorization Code Number (RMA number) is needed from **Spellman** for all returns. The RMA number should be marked clearly on the outside of the shipping container. Packages received without an RMA Number may delay return of the product. The buyer shall pay shipping costs to and from **Spellman**. Customer Service will provide the Standard Cost for out-of-warranty repairs. A purchase order for this amount is requested upon issuance of the RMA Number (in-warranty returns must also be accompanied by a "zero-value" purchase order). A more detailed estimate may be made when the power supply is received at **Spellman**. In the event that the cost of the actual repair exceeds the estimate, **Spellman** will contact the customer to authorize the repair.

### Factory Service Warranty

**Spellman** will warrant for three (3) months or balance of product warranty, whichever is longer, the repaired assembly/part/unit. If the same problem shall occur within this warranty period **Spellman** shall undertake all the work to rectify the problem with no charge and/or cost to the buyer. Should the cause of the problem be proven to have a source different from the one that has caused the previous problem and/or negligence of the buyer, **Spellman** will be entitled to be paid for the repair.

### Spellman Worldwide Service Centers

For a complete listing of **Spellman's** Global Service facilities please go to:  
<http://www.spellmanhv.com/customerservice/service.asp>

THIS INFORMATION CONTAINED HEREIN IS PROPRIETARY TO SPELLMAN HIGH VOLTAGE ELECTRONICS CORP. AND IS TO BE USED ONLY FOR THE PURPOSES INTENDED AND IS NOT TO BE REPRODUCED EITHER IN WHOLE OR PART WITHOUT THE EXPRESS WRITTEN PERMISSION OF SPELLMAN HIGH VOLTAGE ELECTRONICS CORP.

| CONNECTOR LEGEND |                                      |
|------------------|--------------------------------------|
| JB1              | - CUST I/O 25 PIN D MALE             |
| JB2              | - FRONT PANEL 40 PIN 3M              |
| JB3              | - LVPS/FAN PWR/TEMP 12 PIN .156C     |
| JB5              | - HV I/O, BIAS, FIL/DBK 14 PIN .156C |
| TB1              | - CUST INTLK/MONITOR                 |

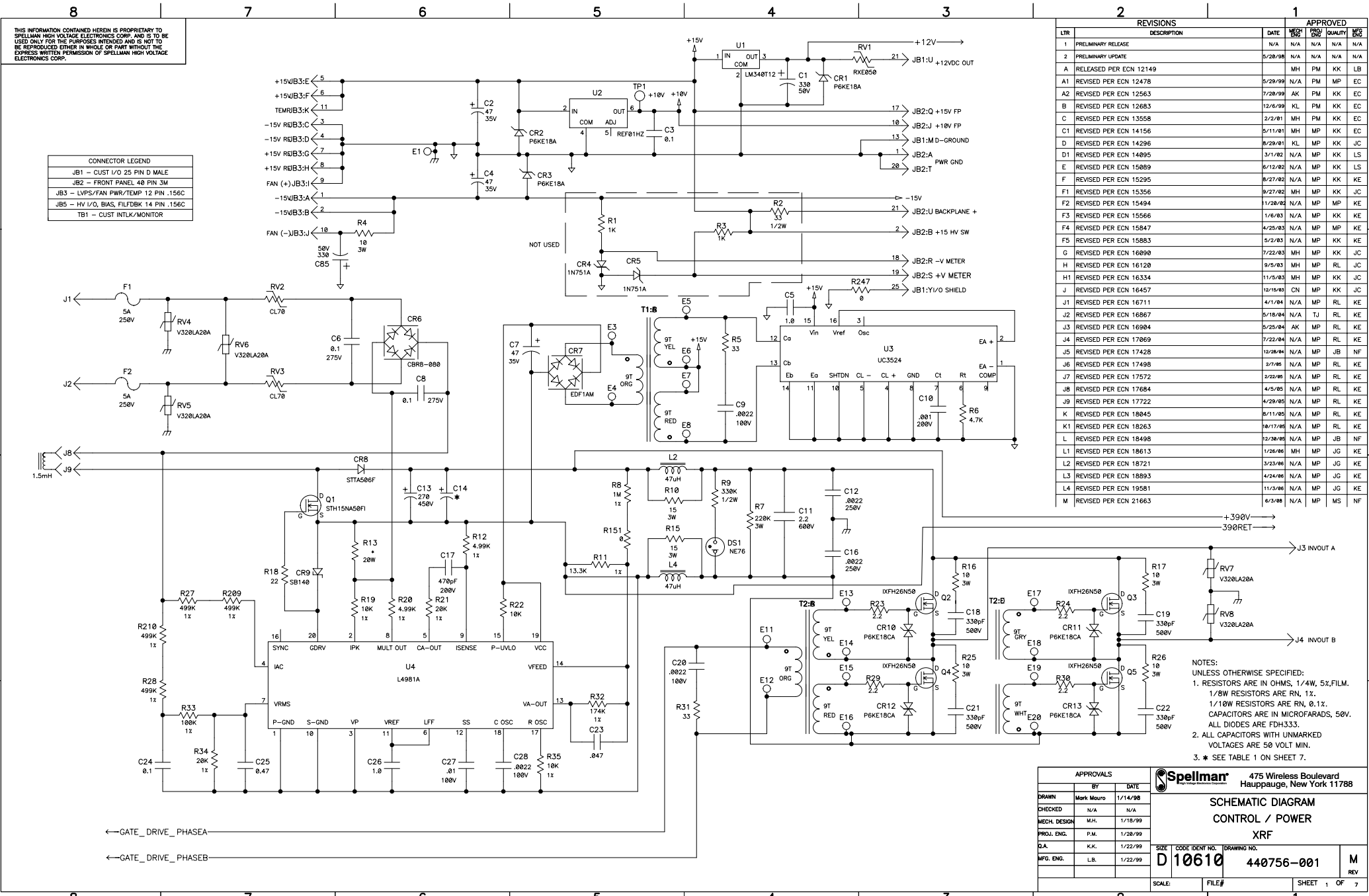

| REVISIONS |                        | APPROVED |     |     |         |     |
|-----------|------------------------|----------|-----|-----|---------|-----|
| LTR       | DESCRIPTION            | DATE     | DES | CHK | QUALITY | MFG |
| 1         | PRELIMINARY RELEASE    | N/A      | N/A | N/A | N/A     | N/A |
| 2         | PRELIMINARY UPDATE     | 5/28/98  | N/A | N/A | N/A     | N/A |
| A         | RELEASED PER ECN 12149 |          | MH  | PM  | KK      | LB  |
| A1        | REVISED PER ECN 12478  | 5/29/99  | N/A | PM  | MP      | EC  |
| A2        | REVISED PER ECN 12563  | 7/28/99  | AK  | PM  | KK      | EC  |
| B         | REVISED PER ECN 12683  | 12/6/99  | KL  | PM  | KK      | EC  |
| C         | REVISED PER ECN 13558  | 2/2/01   | MH  | PM  | KK      | EC  |
| C1        | REVISED PER ECN 14156  | 5/11/01  | MH  | MP  | KK      | EC  |
| D         | REVISED PER ECN 14296  | 8/29/01  | KL  | MP  | KK      | JC  |
| D1        | REVISED PER ECN 14095  | 3/1/02   | N/A | MP  | KK      | LS  |
| E         | REVISED PER ECN 15089  | 6/12/02  | N/A | MP  | KK      | LS  |
| F         | REVISED PER ECN 15295  | 8/27/02  | N/A | MP  | KK      | KE  |
| F1        | REVISED PER ECN 15356  | 9/27/02  | MH  | MP  | KK      | JC  |
| F2        | REVISED PER ECN 15494  | 1/28/03  | N/A | MP  | MP      | KE  |
| F3        | REVISED PER ECN 15566  | 1/6/03   | N/A | MP  | KK      | KE  |
| F4        | REVISED PER ECN 15847  | 4/25/03  | N/A | MP  | MP      | KE  |
| F5        | REVISED PER ECN 15883  | 5/2/03   | N/A | MP  | KK      | KE  |
| G         | REVISED PER ECN 16090  | 7/22/03  | MH  | MP  | KK      | JC  |
| H         | REVISED PER ECN 16128  | 9/5/03   | MH  | PM  | RL      | JC  |
| H1        | REVISED PER ECN 16334  | 11/5/03  | MH  | MP  | KK      | JC  |
| J         | REVISED PER ECN 16457  | 12/15/03 | CN  | MP  | KK      | JC  |
| J1        | REVISED PER ECN 16711  | 4/1/04   | N/A | MP  | RL      | KE  |
| J2        | REVISED PER ECN 16867  | 5/18/04  | N/A | TJ  | RL      | KE  |
| J3        | REVISED PER ECN 16904  | 5/25/04  | AK  | MP  | RL      | KE  |
| J4        | REVISED PER ECN 17069  | 7/22/04  | N/A | MP  | RL      | KE  |
| J5        | REVISED PER ECN 17428  | 12/28/04 | N/A | MP  | JB      | NF  |
| J6        | REVISED PER ECN 17498  | 3/7/05   | N/A | MP  | RL      | KE  |
| J7        | REVISED PER ECN 17572  | 2/22/05  | N/A | MP  | RL      | KE  |
| J8        | REVISED PER ECN 17684  | 4/5/05   | N/A | MP  | RL      | KE  |
| J9        | REVISED PER ECN 17722  | 4/29/05  | N/A | MP  | RL      | KE  |
| K         | REVISED PER ECN 18045  | 8/11/05  | N/A | MP  | RL      | KE  |
| K1        | REVISED PER ECN 18263  | 10/17/05 | N/A | MP  | RL      | KE  |
| L         | REVISED PER ECN 18498  | 12/30/05 | N/A | MP  | JB      | NF  |
| L1        | REVISED PER ECN 18613  | 1/26/06  | MH  | MP  | JG      | KE  |
| L2        | REVISED PER ECN 18721  | 3/23/06  | N/A | MP  | JG      | KE  |
| L3        | REVISED PER ECN 18893  | 4/24/06  | N/A | MP  | JG      | KE  |
| L4        | REVISED PER ECN 19581  | 11/3/06  | N/A | MP  | JG      | KE  |
| M         | REVISED PER ECN 21663  | 6/3/08   | N/A | MP  | MS      | NF  |

NOTES:  
 UNLESS OTHERWISE SPECIFIED:  
 1. RESISTORS ARE IN OHMS, 1/4W, 5% FILM.  
 1/8W RESISTORS ARE RN, 1%.  
 1/10W RESISTORS ARE RN, 0.1%.  
 CAPACITORS ARE IN MICROFARADS, 50V.  
 ALL DIODES ARE FDH333.  
 2. ALL CAPACITORS WITH UNMARKED VOLTAGES ARE 50 VOLT MIN.  
 3. \* SEE TABLE 1 ON SHEET 7.

| APPROVALS   |            |         | Spellman |                | 475 Wireless Boulevard<br>Hauppauge, New York 11788 |     |
|-------------|------------|---------|----------|----------------|---|-----|
| DRAWN       | BY         | DATE    | SIZE     | CODE IDENT NO. | DRAWING NO.   | M   |
| Mark Mauro  | Mark Mauro | 1/14/98 | D        | 10610          | 440756-001  | REV |
| CHECKED     | N/A        | N/A     |          |                |   |     |
| MECH DESIGN | M.H.       | 1/18/99 |          |                |   |     |
| PROJ. ENG.  | P.M.       | 1/28/99 |          |                |   |     |
| D.A.        | K.K.       | 1/22/99 |          |                |   |     |
| MFG. ENG.   | L.B.       | 1/22/99 |          |                |   |     |

THIS INFORMATION CONTAINED HEREIN IS PROPRIETARY TO SPELLMAN HIGH VOLTAGE ELECTRONICS CORP. AND IS TO BE USED ONLY FOR THE PURPOSES INTENDED AND IS NOT TO BE REPRODUCED EITHER IN WHOLE OR PART WITHOUT THE EXPRESS WRITTEN PERMISSION OF SPELLMAN HIGH VOLTAGE ELECTRONICS CORP.

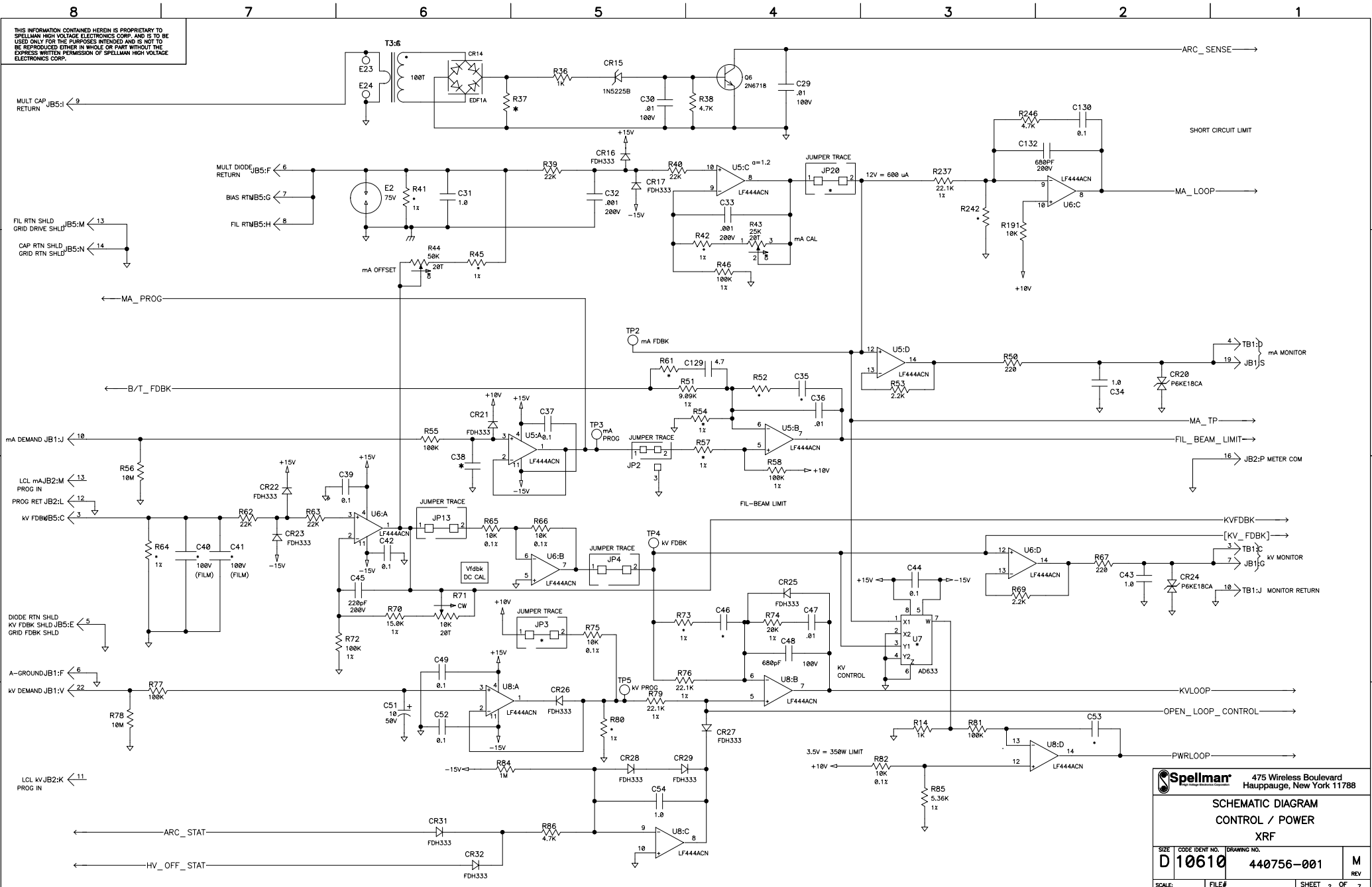

|  |                                     |   |                   |
|--|-------------------------------------|---|-------------------|
|  |                                     | 475 Wireless Boulevard<br>Hauppauge, New York 11788 |                   |
| <b>SCHEMATIC DIAGRAM</b><br><b>CONTROL / POWER</b><br><b>XRF</b> |                                     |   |                   |
| SIZE<br><b>D 10610</b>   | CODE IDENT NO.<br><b>440756-001</b> | DRAWING NO.<br><b>M</b>                             | REV<br><b>REV</b> |
| SCALE:   | FILE#                               | SHEET 2   | OF 7              |

THIS INFORMATION CONTAINED HEREIN IS PROPRIETARY TO SPELLMAN HIGH VOLTAGE ELECTRONICS CORP. AND IS TO BE USED ONLY FOR THE PURPOSES INTENDED AND IS NOT TO BE REPRODUCED EITHER IN WHOLE OR PART WITHOUT THE EXPRESS WRITTEN PERMISSION OF SPELLMAN HIGH VOLTAGE ELECTRONICS CORP.

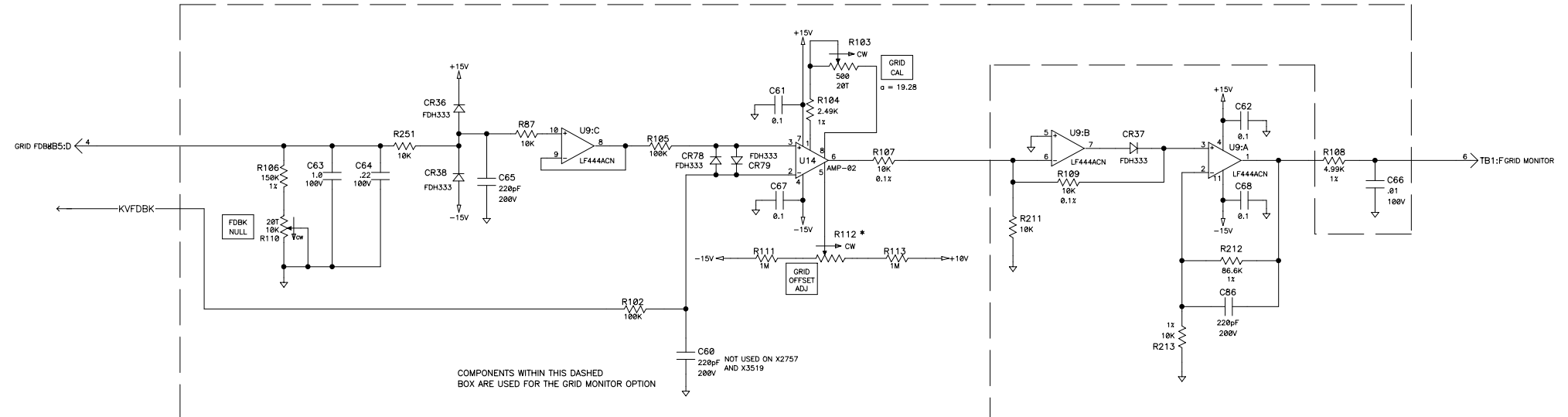
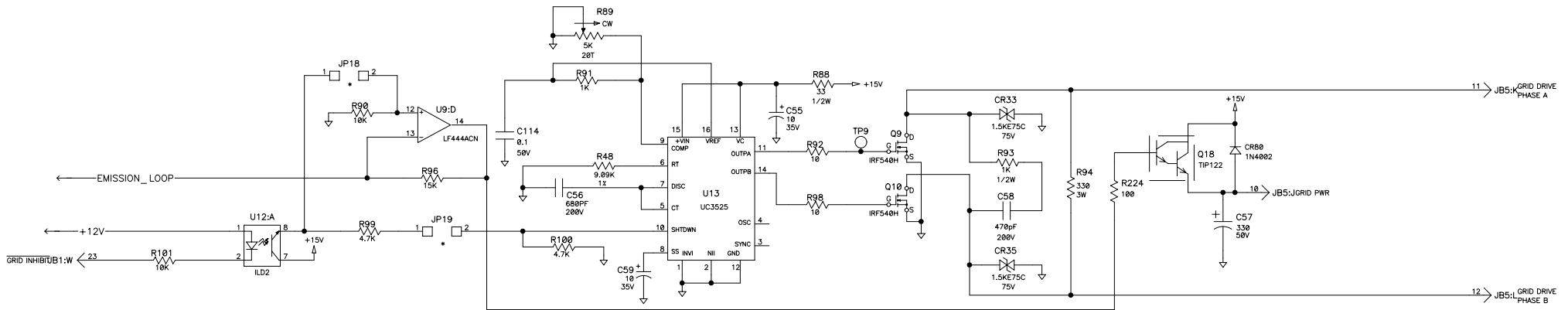

|                          |                |   |        |
|--------------------------|----------------|---|--------|
| <b>Spellman</b>          |                | 475 Wireless Boulevard<br>Hauppauge, New York 11788 |        |
| <b>SCHEMATIC DIAGRAM</b> |                |   |        |
| <b>CONTROL / POWER</b>   |                |   |        |
| <b>XRF</b>               |                |   |        |
| SIZE                     | CODE IDENT NO. | DRAWING NO.   |        |
| D                        | 10610          | 440756-001  |        |
|                          |                | M   | REV    |
| SCALE:                   | FILE#          | SHEET   | 3 OF 7 |



THIS INFORMATION CONTAINED HEREIN IS PROPRIETARY TO SPELLMAN HIGH VOLTAGE ELECTRONICS CORP. AND IS TO BE USED ONLY FOR THE PURPOSES INTENDED AND IS NOT TO BE REPRODUCED EITHER IN WHOLE OR PART WITHOUT THE EXPRESS WRITTEN PERMISSION OF SPELLMAN HIGH VOLTAGE ELECTRONICS CORP.

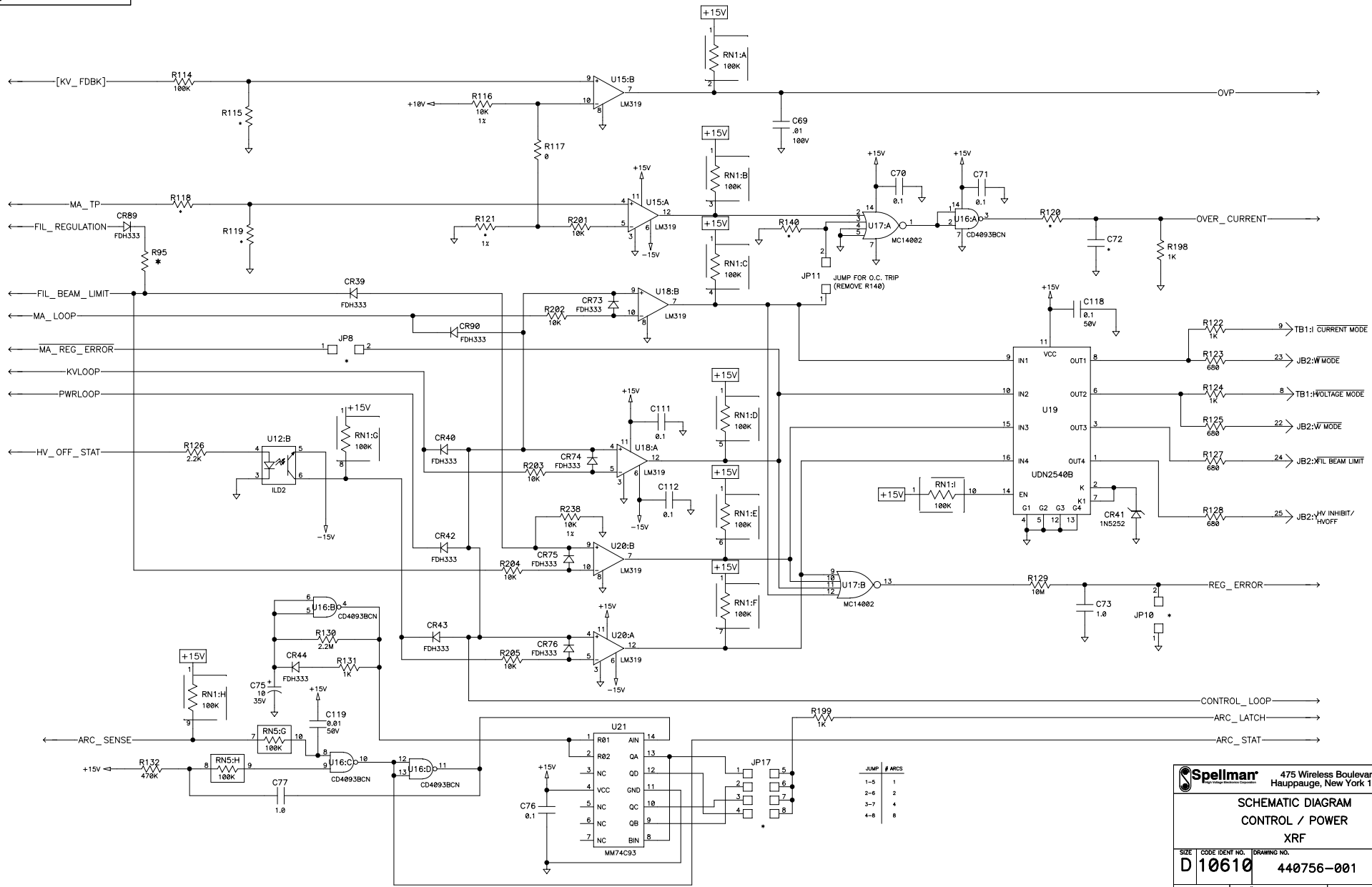

| JUMP | # ARCS |
|------|--------|
| 1-5  | 1      |
| 2-6  | 2      |
| 3-7  | 4      |
| 4-8  | 8      |

475 Wireless Boulevard  
 Hauppauge, New York 11788

**SCHEMATIC DIAGRAM**  
**CONTROL / POWER**  
**XRF**

|         |                |             |     |
|---------|----------------|-------------|-----|
| SIZE    | CODE IDENT NO. | DRAWING NO. | REV |
| D110610 |                | 440756-001  | M   |

SCALE: FILE# SHEET 4 OF 7

THIS INFORMATION CONTAINED HEREIN IS PROPRIETARY TO SPELLMAN HIGH VOLTAGE ELECTRONICS CORP. AND IS TO BE USED ONLY FOR THE PURPOSES INTENDED AND IS NOT TO BE REPRODUCED EITHER IN WHOLE OR PART WITHOUT THE EXPRESS WRITTEN PERMISSION OF SPELLMAN HIGH VOLTAGE ELECTRONICS CORP.

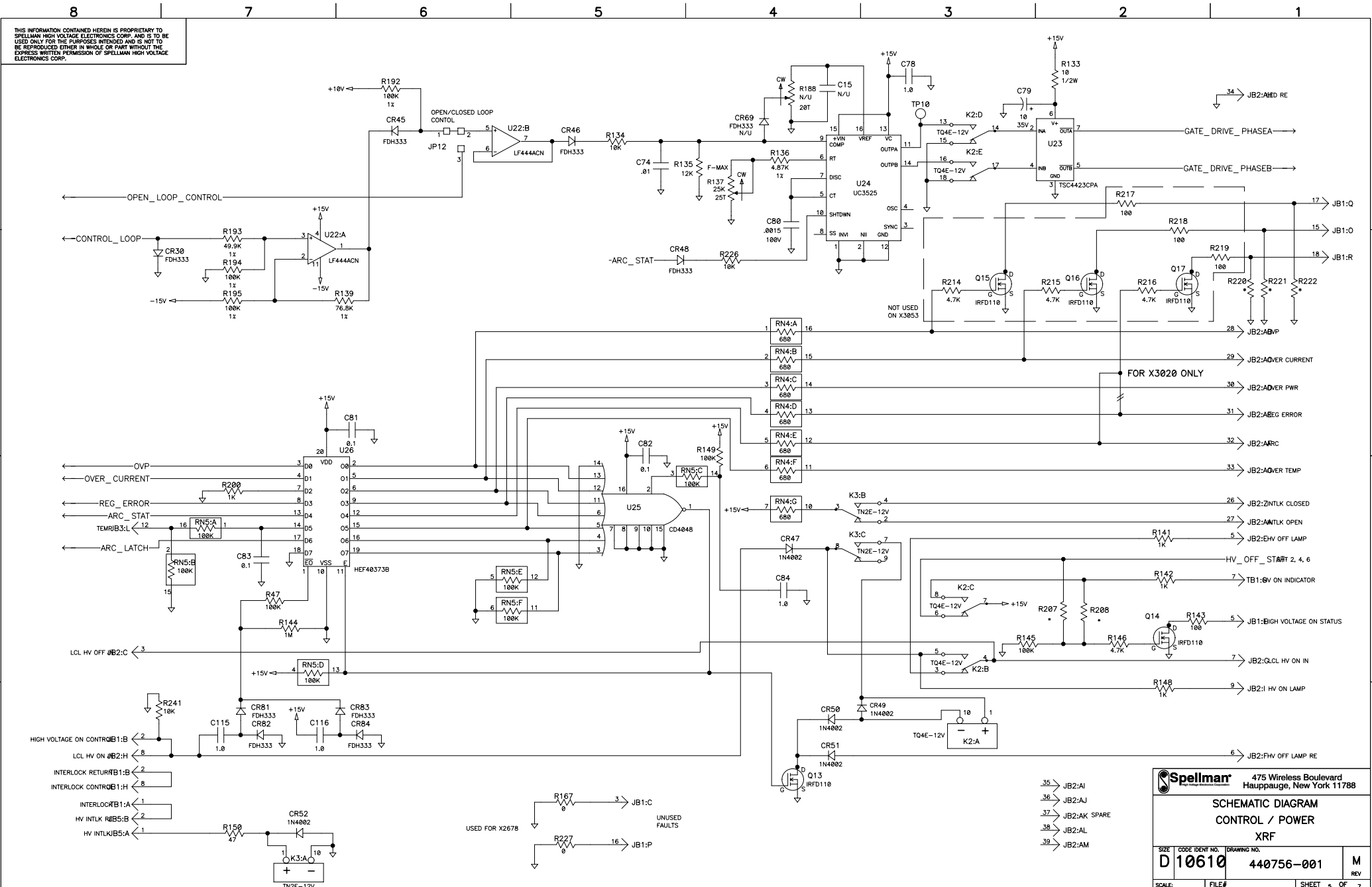

**Spellman** 475 Wireless Boulevard  
Hauppauge, New York 11788

**SCHEMATIC DIAGRAM**  
CONTROL / POWER  
XRF

|      |                |             |
|------|----------------|-------------|
| SIZE | CODE IDENT NO. | DRAWING NO. |
| D    | 10610          | 440756-001  |
| M    | REV            |             |

SCALE: FILE# SHEET 5 OF 7

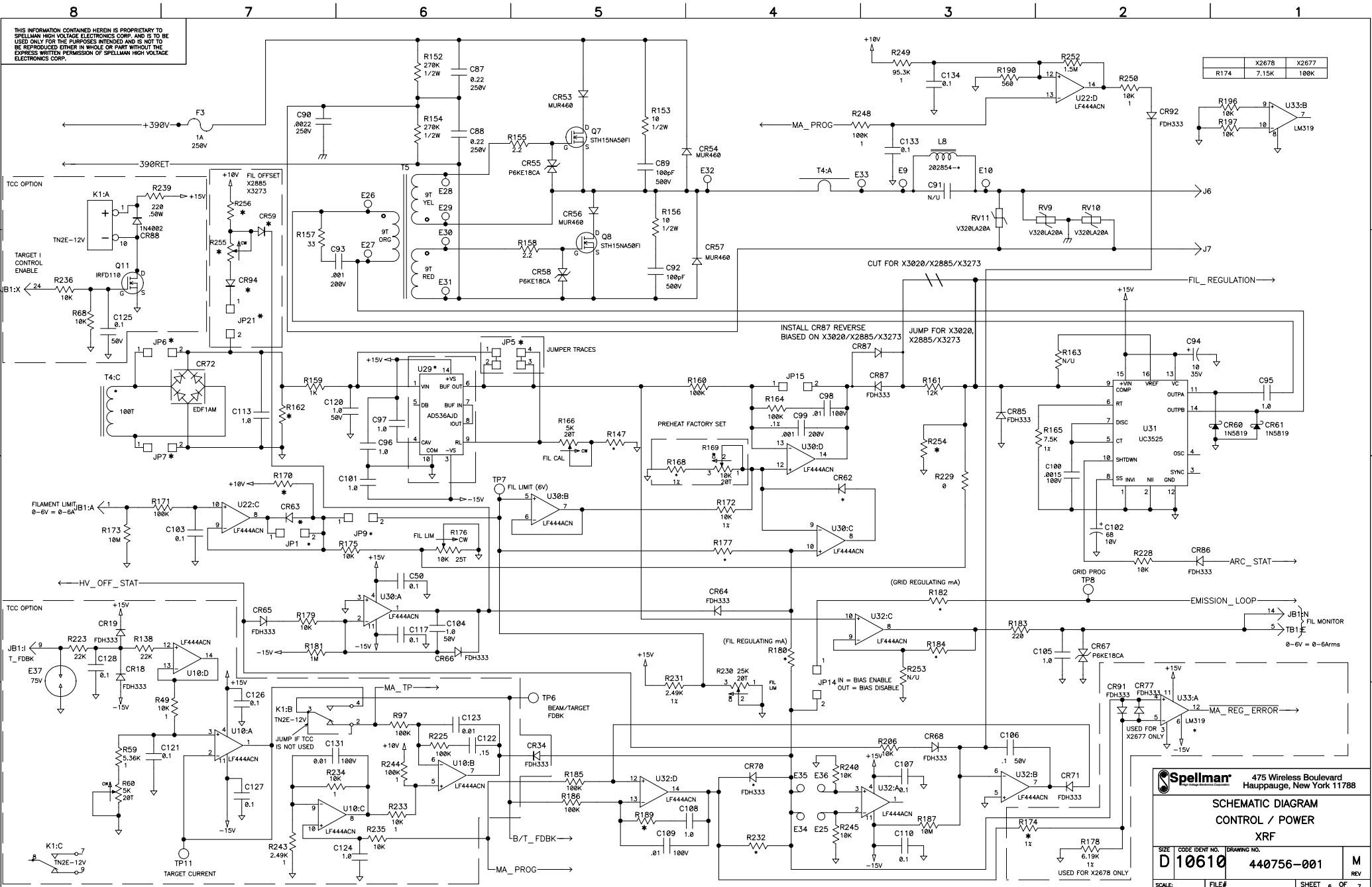

THIS INFORMATION CONTAINED HEREIN IS PROPRIETARY TO SPELLMAN HIGH VOLTAGE ELECTRONICS CORP. AND IS TO BE USED ONLY FOR THE PURPOSES INTENDED AND IS NOT TO BE REPRODUCED EITHER IN WHOLE OR PART WITHOUT THE EXPRESS WRITTEN PERMISSION OF SPELLMAN HIGH VOLTAGE ELECTRONICS CORP.

|      |       |       |
|------|-------|-------|
| R174 | X2678 | X2677 |
|      | 7.15K | 100K  |

**Spellman** 475 Wireless Boulevard  
Hauppauge, New York 11788

**SCHEMATIC DIAGRAM**  
CONTROL / POWER  
XRF

|        |                |             |     |
|--------|----------------|-------------|-----|
| SIZE   | CODE IDENT NO. | DRAWING NO. | REV |
| D10610 | 440756-001     |             | M   |

SCALE: FILE# SHEET 6 OF 7

USED FOR X2677 ONLY

8

7

6

5

4

3

2

1

THIS INFORMATION CONTAINED HEREIN IS PROPRIETARY TO SPELLMAN HIGH VOLTAGE ELECTRONICS CORP. AND IS TO BE USED ONLY FOR THE PURPOSES INTENDED AND IS NOT TO BE REPRODUCED EITHER IN WHOLE OR PART WITHOUT THE EXPRESS WRITTEN PERMISSION OF SPELLMAN HIGH VOLTAGE ELECTRONICS CORP.

TABLE 1

Table with columns for ASSY 450015 and rows for MODEL, C14, C35, C38, C40, C41, C46, C53, C72, C129, CR62, CR63, CR70, JP1, JP2, JP3, JP4, JP5, JP6, JP7, JP8, JP9, JP10, JP11, JP12, JP13, JP14, JP15, JP17, JP18, JP19, JP20, R13, R37, R41, R42, R45, R52, R54, R57, R61, R64, R73, R80, R95, R112, R115, R118, R119, R120, R121, R140, R147, R162, R168, R170, R174, R177, R180, R182, R184, R189, R207, R208, R220, R221, R222, R232, R242, R253, R254, U7, U29, U33, L8.

N/U = NOT USED

\* P/O ARTWORK PINS 1-2

\*\*P/O ARTWORK PINS 1 THRU 4

TABLE 1 (CONT'D)

Table with columns for ASSY 450015 and rows for MODEL, CR59, CR94, JP21, R255, R256.

Spare Gate Table

Table with columns: Last Used, Not Used, Spare Gates. Rows include C134, CR94, DS1, E37, F3, J9, JB5, JP21, K3, L8, Q18, R256, RN5, RV11, T5, TB1, TP11, U33.

Spellman 475 Wireless Boulevard Hauppauge, New York 11788

SCHEMATIC DIAGRAM CONTROL / POWER XRF

Form with fields: SIZE D10610, CODE IDENT NO. 440756-001, DRAWING NO. M, REV. SCALE, FILE#, SHEET 7 OF 7.

8

7

6

5

4

3

2

1